

Induction Motor Fed With Matrix Converter

Makrani Mumtaz. M & V. J. Rupapara

Power Electronics Dept, Gujarat Technological University, Gujarat-India
E-mail: mumtaz.makrani@gmail.com , e-mail: drivecon@yahoo.co.in

Abstract - The output voltages of the variable voltage and variable frequency voltage sources employing voltage source inverter is non sinusoidal. The output current of a variable frequency current source using current source inverter is also non sinusoidal. When the induction motor is fed by using these inverters odd harmonics will be present in the input supply, because of these inverters output voltage is non sinusoidal. This harmonics do not contribute the output power of the motor, they produce additional losses in the machine. This harmonic losses reduces the efficiency and cause derating of the motor. These limitations can be overcome by using matrix converter because of its unique feature is pure sinusoidal as output. The matrix converter is superior than inverter drives because of its regeneration ability and four-quadrant operation. Therefore it meets the stringent energy efficiency and power quality.

Index Terms—Non-sinusoidal supply, Matrix Converter, Induction Motor, Simulation, Harmonics, Malab/Simulink.

I. INTRODUCTION

The diode rectifier front – end of the PWM inverters fed harmonics to the utility grid and pollute the AC line such that other equipment on the same line experience interference and have operating problems such as common failure, Electro Magnetic Interference. Further more they have no regeneration capability and in most applications with frequent regeneration operating mode, the regenerated energy is dissipated in a resistive circuit with limited capacity.

The physical realization of the matrix converter is not straightforward, due to the fact that there are no freewheeling paths. In addition, the number of devices in the power circuit is high compared with that in the inverter. Consequently, the timing of the switch actuation signals is particularly critical, and protection of the circuit under fault conditions requires very careful consideration [7]. In [8], a highly compact converter using novel high-power 3-in-1 integrated power modules was used. In another paper, the

integration of the matrix converter and the induction motor in a single unit was discussed [9].

The first matrix converter contained in a single power module using insulated gate bipolar transistor technology was presented in [10]. There is now competition between the matrix converter and the voltage source inverter with a regenerative input rectifier. Only a few technical papers have dealt with the dynamic behaviour analysis of the field-oriented controlled matrix converter motor drive. In [11, 12], a simulation of the matrix converter feeding an induction motor was performed. and in [13], a control technique for compensating the effects of the input voltage variations on the matrix converter algorithms was described, but closed loop operation was not considered.

The serious drawback of PWM inverters is that the output voltage is non sinusoidal. The operation of an induction motor with non-sinusoidal supply causes significant reduction in motor efficiency and motor derating. A non-sinusoidal[7] waveform resolved into fundamental and harmonic components using Fourier analysis is, because of the

$$I_s = \sum_{n=1}^{\infty} a_n \sin n\omega t + \sum_{n=1}^{\infty} b_n \cos n\omega t \quad (1)$$

half wave symmetry[7] as in (1). where,

$$a_n = \frac{1}{\pi} \int_0^{2\pi} I_s \sin n\omega t \, d(\omega t)$$

$$b_n = \frac{1}{\pi} \int_0^{2\pi} I_s \cos n\omega t \, d(\omega t)$$



Fig.1 K^{th} harmonic equivalent circuit of induction motor

The rms value of nth harmonic in the source current is

$$I_n = \frac{1}{\sqrt{2}} [a_n^2 + b_n^2]^{1/2} \quad (2)$$

found by using (1) and (2). The phase displacement of the nth

$$\phi_n = \tan^{-1} \frac{b_n}{a_n} \quad (3)$$

harmonic given in (3), because of the half wave symmetry only odd harmonics will be present such as positive 5th, negative 7th and zero sequence harmonics[7]. While harmonics do not contribute to the output power of the motor. They certainly produce additional losses in the motor. The Kth harmonic equivalent circuit of induction motor[6] shown in Fig.1 and the

$$P_h = \sum_{k=5,7} I_{sk}^2 (R_{sk} + R'_{sk}) \quad (4)$$

harmonic copper loss is given in (4). where,

$$I_{sk} \cong \frac{V_k}{k(X_s + X'_r)}$$

here, k = Harmonic sequence

This harmonic loss reduces efficiency and increase thermal loading. The higher the harmonic content, the greater the reduction in efficiency and the increase in thermal loading even at light loads. The mmf and air-gap flux waves produced by different harmonics[7] including fundamental are not stationary relative to each other. Consequently they produce pulsating harmonics, which have zero average value.

The negative sequence fifth harmonic air-gap flux wave produces a rotor mmf wave that moves backward at five times the fundamental synchronous speed[6]. The relative speed between the fifth harmonic rotor mmf wave and the fundamental air gap flux wave being six times the

fundamental synchronous speed, their interaction produces a pulsating torque at six times the fundamental frequency.

The positive sequence seventh harmonic air-gap flux wave produces a rotor mmf wave, which rotates forward at seven times the fundamental synchronous speed. Since the relative speed between the fundamental air-gap flux wave and the seventh harmonic rotor mmf wave is six times the fundamental synchronous speed, their interaction also produces a pulsating torque at six times the fundamental frequency. Similarly the eleventh and thirteenth harmonics produce a torque pulsation twelve times the fundamental frequency, but its amplitude is small. The torque pulsations cause fluctuations in motor speed. When the fundamental frequency is sufficiently large, speed fluctuations are sufficiently low because of the motor inertia. When the fundamental frequency and the motor speed are low, large fluctuations in motor speed are obtained producing a jerky or stepped motion[7]. The amplitude of the torque pulsations depends on the corresponding harmonic voltages and the motor reactance.

The solution for these limitations is achieved by the operation of induction motor by using matrix converter. Because this is the only one AC-AC single stage converter[9] capable to supply pure sinusoidal as input to the induction motor. The trend in power electronics is toward, improving the interaction with the power grid, providing bi-directional power flow, increasing the efficiency of drive while operating at higher switching frequency and decreasing the drive size all of which match the profile of a matrix converter. Compared with other conventional drives there is potential for reduced cost of manufacture and maintenance, and increased power / weight and power / volume ratios. The circuit of the matrix converter is capable to connect the load to the grid directly and inherently bi-directional power flow also offers sinusoidal input current without the harmonics, associated with present in commercial inverters.

II. ALGORITHM OF MATRIX CONVERTER

A simplified version of the Venturini algorithm is used in this work [17]. This algorithm is defined in terms of the three-phase input and output voltages at each sampling instant and is convenient for closed loop operations. For the real-time implementation of the proposed modulation algorithm, it is required to measure any two of three input line-to-line voltages. Then, V_{lm} and ω_{it} are calculated as

$$V_{lm}^2 = \frac{2}{3}(v_{AB}^2 + v_{BC}^2 + v_{AC}^2) \quad (5)$$

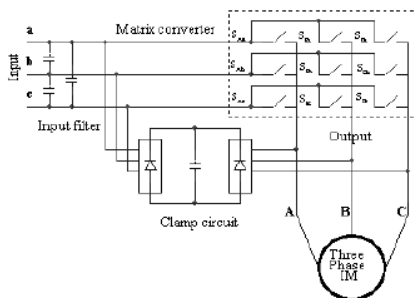

Fig.2 The practical scheme of matrix converter drive

$$\omega t = \arctan\left(\frac{v_{bc}}{\sqrt{v_a^2 + v_b^2 + v_c^2}}\right) \quad (6)$$

where v_{AB}, v_{BC} are the instantaneous input line voltages.

The target output peak voltage and the output position are calculated as

$$V_{om}^2 = \frac{2}{3}(v_a^2 + v_b^2 + v_c^2) \quad (7)$$

$$\omega_o t = \arctan\left(\frac{v_b - v_c}{\sqrt{3}v_a}\right) \quad (8)$$

where v_a, v_b, v_c are the target phase output voltages.

Alternatively, in a closed loop system (for example a fieldoriented controlled drive), the voltage magnitude and angle may be direct outputs of the control loop.

Then, the voltage ratio is calculated as

$$q = \sqrt{\frac{V_{om}^2}{V_{im}^2}} \quad (9)$$

where q is the desired voltage ratio, and V_{im} is the peak input voltage.

Triple harmonic terms are found

$$K_{31} = \frac{2}{9} \frac{q}{q_m} \sin(\omega_o t) \sin(3\omega t) \quad (10)$$

$$K_{32} = \frac{2}{9} \frac{q}{q_m} \sin\left(\omega_o t - \frac{2\pi}{3}\right) \sin(3\omega t) \quad (11)$$

$$K_{33} = -\sqrt{V_{om}^2} \left[\frac{1}{6} \cos(3\omega_o t) - \frac{1}{4} \frac{1}{q_m} \cos(3\omega t) \right] \quad (12)$$

where q_m is the maximum voltage ratio (0.866).

Then, the three modulation functions for output phase a are given as

$$M_{a0} = \frac{1}{3} + k_{31} + \frac{2}{3V_{im}^2} (v_a + k_{33}) \left(\frac{2}{3} v_{aB} + \frac{1}{3} v_{aC} \right) \quad (13)$$

$$M_{a1} = \frac{1}{3} + k_{32} + \frac{2}{3V_{im}^2} (v_a + k_{33}) \left(\frac{2}{3} v_{bC} - \frac{1}{3} v_{aB} \right) \quad (14)$$

$$M_{a2} = 1 - (M_{a0} + M_{a1}) \quad (15)$$

The modulation functions for the other two output phases, b and c are obtained by replacing v_b and v_c with v_a , respectively in Equations (9) and (10). Note that the modulation functions have third harmonic components at the input and output frequencies added to them to produce output voltage, v_o . This is a requirement to get the maximum possible voltage ratio [7]. It should be noted that in Eq. (3) there is no requirement for the target outputs to be sinusoidal. In general, three phase output voltages and input currents

can be defined in terms of the modulation functions in matrix form as

$$v_{oph} = M v_{iph} \\ \begin{bmatrix} v_a \\ v_b \\ v_c \end{bmatrix} = \begin{bmatrix} M_{a0} & M_{a1} & M_{a2} \\ M_{b0} & M_{b1} & M_{b2} \\ M_{c0} & M_{c1} & M_{c2} \end{bmatrix} \begin{bmatrix} v_A \\ v_B \\ v_C \end{bmatrix} \quad (16)$$

$$i_{ph} = M^T i_{oph} \\ \begin{bmatrix} i_A \\ i_B \\ i_C \end{bmatrix} = \begin{bmatrix} M_{a0} & M_{b0} & M_{c0} \\ M_{a1} & M_{b1} & M_{c1} \\ M_{a2} & M_{b2} & M_{c2} \end{bmatrix} \begin{bmatrix} i_a \\ i_b \\ i_c \end{bmatrix} \quad (17)$$

where the superscript T denotes a transpose, and M is the instantaneous input-phase to output-phase transfer matrix of the three-phase matrix converter. v_{iph} and v_{oph} are the input and output phase voltage vectors, and i_{iph} and i_{oph} represent the input and output phase current vectors. Alternatively, from Equations (12) and (13), the output-line voltages and input-line currents can be expressed as

$$v_{oLine} = m v_{iLine} \\ \begin{bmatrix} v_{aB} \\ v_{bC} \\ v_{cA} \end{bmatrix} = \begin{bmatrix} m_{aB} & m_{bB} & m_{cB} \\ m_{aC} & m_{bC} & m_{cC} \\ m_{aA} & m_{bA} & m_{cA} \end{bmatrix} \begin{bmatrix} v_{AB} \\ v_{BC} \\ v_{CA} \end{bmatrix} \quad (18)$$

$$i_{iLine} = m^T i_{oLine} \\ \begin{bmatrix} i_{aB} \\ i_{bC} \\ i_{cA} \end{bmatrix} = \begin{bmatrix} m_{aB} & m_{aC} & m_{aA} \\ m_{bB} & m_{bC} & m_{bA} \\ m_{cB} & m_{cC} & m_{cA} \end{bmatrix} \begin{bmatrix} i_{aB} \\ i_{bC} \\ i_{cA} \end{bmatrix} \quad (19)$$

Where

$$\begin{aligned} m_{aB} &= \frac{1}{3}(M_{a0} - M_{a1}) - \frac{1}{3}(M_{b0} - M_{b1}) \\ m_{aC} &= \frac{1}{3}(M_{a0} - M_{a1}) - \frac{1}{3}(M_{c0} - M_{c1}) \\ m_{aA} &= \frac{1}{3}(M_{a0} - M_{a1}) - \frac{1}{3}(M_{a0} - M_{a1}) \\ m_{bB} &= \frac{1}{3}(M_{b0} - M_{b1}) - \frac{1}{3}(M_{b0} - M_{b1}) \\ m_{bC} &= \frac{1}{3}(M_{b0} - M_{b1}) - \frac{1}{3}(M_{c0} - M_{c1}) \\ m_{bA} &= \frac{1}{3}(M_{b0} - M_{b1}) - \frac{1}{3}(M_{a0} - M_{a1}) \\ m_{cB} &= \frac{1}{3}(M_{c0} - M_{c1}) - \frac{1}{3}(M_{c0} - M_{c1}) \\ m_{cC} &= \frac{1}{3}(M_{c0} - M_{c1}) - \frac{1}{3}(M_{a0} - M_{a1}) \\ m_{cA} &= \frac{1}{3}(M_{c0} - M_{c1}) - \frac{1}{3}(M_{b0} - M_{b1}) \end{aligned} \quad (20)$$

III. d-q MODEL OF INDUCTION MOTOR

The simulation equations for an induction motor in the d-q synchronously rotating reference frame are given as [11]

$$\begin{bmatrix} V_{sq} \\ V_{sd} \\ 0 \\ 0 \end{bmatrix} = \begin{bmatrix} R_s & 0 & 0 & 0 \\ 0 & R_r & 0 & 0 \\ 0 & 0 & R_r & 0 \\ 0 & 0 & 0 & R_r \end{bmatrix} \begin{bmatrix} I_{sq} \\ I_{sd} \\ I_{rq} \\ I_{rd} \end{bmatrix} + \begin{bmatrix} p & \omega_s & 0 & 0 \\ -\omega_s & p & 0 & 0 \\ 0 & 0 & p & (\omega_s - \omega_r) \\ 0 & 0 & -(\omega_s - \omega_r) & p \end{bmatrix} \begin{bmatrix} \psi_{sq} \\ \psi_{sd} \\ \psi_{rq} \\ \psi_{rd} \end{bmatrix} \quad (21)$$

$$\begin{bmatrix} \psi_{sq} \\ \psi_{sd} \\ \psi_{rq} \\ \psi_{rd} \end{bmatrix} = \begin{bmatrix} L_s & 0 & L_{s\sigma} & 0 \\ 0 & L_r & 0 & L_{r\sigma} \\ L_{\sigma} & 0 & L_r & 0 \\ 0 & L_{\sigma} & 0 & L_r \end{bmatrix} \begin{bmatrix} I_{sq} \\ I_{sd} \\ I_{rq} \\ I_{rd} \end{bmatrix} \quad (22)$$

$$\begin{aligned} L_s &= L_{ls} + L_{\sigma} \\ L_r &= L_{lr} + L_{\sigma} \end{aligned} \quad (23)$$

$$T_e = 3 \frac{P L_{\sigma}}{2 L_r} (I_{sq} \psi_{rd} - I_{sd} \psi_{rq}) \quad (24)$$

$$J \frac{d\omega_{mech}}{dt} = T_e - T_L - f_v \omega_{mech} \quad (25)$$

where quantities with subscript q or d denote q axis or d axis quantities and quantities with subscript s or r denote stator or rotor quantities. Ψ denotes flux linkage, R is resistance, L_{ls} and L_{lr} are the stator and rotor leakage inductances, respectively, and L_{σ} is the magnetizing inductance. L_s and L_r denote the self inductances of the stator and rotor, respectively. T_e and T_L are the motor torque and load torque, respectively. P is the number of poles, and f_v is the friction constant coefficient. J is inertia and ω_{mech} is the mechanical speed of the motor. All rotor quantities are referred to the stator.

IV. MATRIX CONVERTER

Matrix Converter (MC) is a new type of direct AC/AC converter[1],[4] which converts input line voltage into variable voltage with unrestricted frequency without using an intermediate DC link circuit. MC is an array of controlled semiconductor switches that connects directly the three-phase source to three-phase load. A three-phase MC consists of nine bi-directional voltage-blocking switches, arranged in three groups of three each group being associated with an output line. This arrangement of bi-directional switches connects any of the input line a, b or c to any of the output line A, B or C as schematically represented in Fig.2.

In order to provide safe operation of the converter when operating with bi-directional switches two basic rules[10] must be followed. Normally the MC is fed by a voltage source and for this reason, the input terminals should not be short circuited. Further more, the load has typically an inductive nature and for this reason an output phase must never be opened. According to the basic rule, the maximum number of permitted switching states of the MC is reduced to 27. First 6 switching states provide a direct connection of each output line to a different input line producing a rotating voltage vector with same amplitude and same frequency of the input voltage system and direction dependent on the sequence. Another 18 switching states produce active vectors of variable depending on the selected line-to-line voltage but at a stationary position. The last 3 switching states produce a zero vector, by connecting all the output lines to the same input line.

An input filter is necessary to the high frequency ripple from the input current because the matrix converter is capable to connect the load to the grid directly. For protection purposes a clamp circuit is needed to provide safe shut down of the converter during over current on the output side or voltage disturbances on the input side.

Bi-directional Switches

The switches must be able to block voltage and current in both of its directions[10]. They are named bi directional switches. The development of the matrix converter has been obstructed the lack of a forced commutated bi-directional switch. By using unidirectional switches, there are three ways to obtain a bi-directional switch

- The diode embedded unidirectional switch.
- The two Common Emitter (CE) bi-directional switch
- The two Common Collector(CC) bi-directional switch.

The first topology implies higher conduction losses through two FRDs and one IGBT. It has higher switching losses. The other two topologies based on anti-series connection of two unidirectional switches (CE and CC)

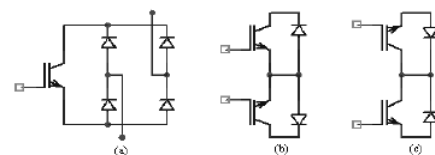

Fig.3 Bi-directional switch topologies using unidirectional switches: a) diode embedded; b) common emitter(CE); c) common collector(CC).

allow for lower conduction losses through one FRD and one IGBT as shown in Fig 3. This figure shows the different topologies of bi-directional switches. The CC topology is very easy to build the converter in a modular structure as required for high power and this topology is the most favoured combination for low power industrial usage.

B. Input Filter

Matrix Converter has the tendency to draw the input from the Grid directly. Because of the matrix converter is connected to the grid, an input filter[1] is necessary to reduce the switching harmonics present in the input current. The requirements for the filter

1. To have the cut-off frequency lower than the switching frequency of the converter.
2. To minimize it reactive power at the grid frequency.
3. To minimize the volume and weight for capacitors and chokes (inductors).
4. To minimize the filter inductance voltage drop at rated current (in order to avoid a reduction in the voltage transfer ratio). Filter doesn't used to store energy from the load.

C. Clamp Circuit

In matrix converter over voltages can appear from the input side originated by the line or Grid perturbations. Further dangerous over voltages can appear from the output side caused by an over current fault. A clamp circuit[10] is the most common solution to avoid over voltages coming from the grid and from the motor. The clamp circuit consists of 12 Fast Recovery Diodes (FRD) to connect the capacitor to the input and output terminals.

V. MODULATION TECHNIQUE OF THREE PHASE TO THREE PHASE MATRIX CONVERTER

The Matrix Converter[1] connects any output line to any input line by means of nine bi-directional switches[10]. To consider the modulation problem assume that the switches in the converter are ideal and balanced the input supply.

The input voltages are in (26),

$$\begin{bmatrix} V_a(t) \\ V_b(t) \\ V_c(t) \end{bmatrix} = V_{im} \begin{bmatrix} \cos(\omega_1 t) \\ \cos(\omega_1 t + 2\pi/3) \\ \cos(\omega_1 t + 4\pi/3) \end{bmatrix} \quad (26)$$

The venturini algorithm provides a control of switches[1] like SAa, SBa etc. so that the low frequency parts of the synthesized output voltages VA, VB, VC and input currents are purely sinusoidal with the prescribed output frequency, input frequency amplitude and input displacement factor. The switches on each output phase are closed sequentially and respectively.

The sequence time Ts is defined as the sum of the switching times in (27). For safe operation of the

$$T_s = t_{Aa} + t_{Ab} + t_{Ac} = t_{Ba} + t_{Bb} + t_{Bc} = t_{Ca} + t_{Cb} + t_{Cc} = 1/f_s \quad (27)$$

where, fs is the switching frequency and is constant

tAa is the on time for switch SAa.system, the MC input terminals must not be

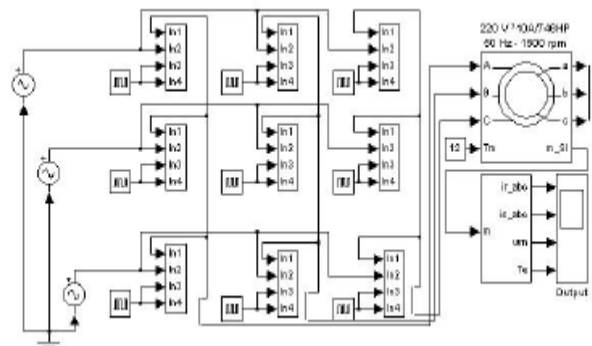

Fig.4 Block diagram of matrix converter fed Induction motor drive

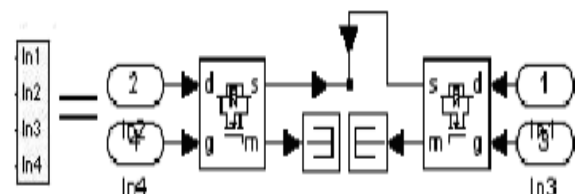

Fig.5 Subsystem of bi-directional switch

short-circuited and the output terminals must not be open-circuited through bi-directional switches of MC.

For unity input displacement factor the duty cycle for the switch connected between the input phase β and output phase

$$T_{\gamma\beta} = T_s \left[\frac{1}{3} + \frac{2V_{o\gamma} V_{i\beta}}{3V_{im}^2} + \frac{2q}{3q_m} \sin(\omega_1 t + \psi_\beta) \sin(3\omega_1 t) \right] \quad (7)$$

γ can be defined as, where

$\psi_{\beta} : 0,2\pi/3,4\pi/3$ corresponding to the input phases a, b and c respectively.

$$V_{\alpha\gamma} = qV_{\alpha\beta} \left[\cos(\alpha_2 t + \psi_{\gamma}) - \frac{1}{6} \cos(3\alpha_2 t) + \frac{1}{4I_{\alpha\beta}} \cos(3\alpha_2 t) \right] \quad (8)$$

Equations (7) and (8) used for the duty cycle calculation[8],

of the switches in the implementation of open-loop control of Matrix Converter fed induction Motor drive[2].

VI. INDUCTION MOTOR

This paper is also describes modeling the induction motor based on the three-phase to three-phase matrix converter output and to investigate the torque pulsating, motor derating and over all efficiency when the induction motor is fed by Matrix Converter. The electromagnetic forces of induction motor equivalent circuit are calculated as the functions of stator and rotor fluxes. This and some other variations of the three-phase model of an induction motor are developed and simulated by authors of this paper. The simulations have been carried out assuming a sampling period of 500us. Simulink induction machine model is also available in the Matlab / simulink –power system block sets and in the literature [3],[5]and [11]. The block diagram of MC fed induction motor and subsystem of BDS is shown in Fig.4 and Fig.5 respectively. The reason for choosing simulink set motor model is it describes both steady state and transient behavior. But in PSPICE software[2] model describes only steady state behavior of the motor.

VII. SIMULINK AND SIMULATION RESULTS

The proposed target has been extensively investigated under system circuit level simulations. The system level simulation is made utilizing Matlab / Simulink

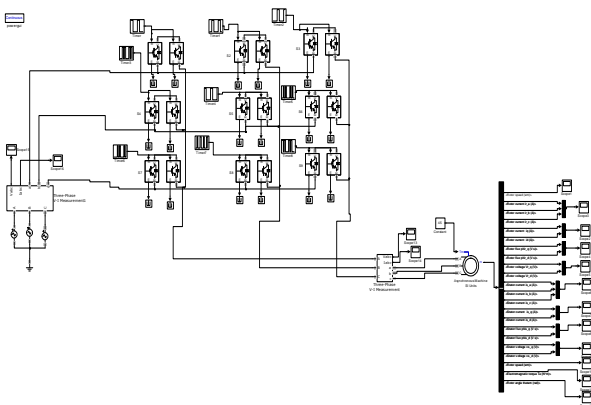

Fig5. Simulink Model

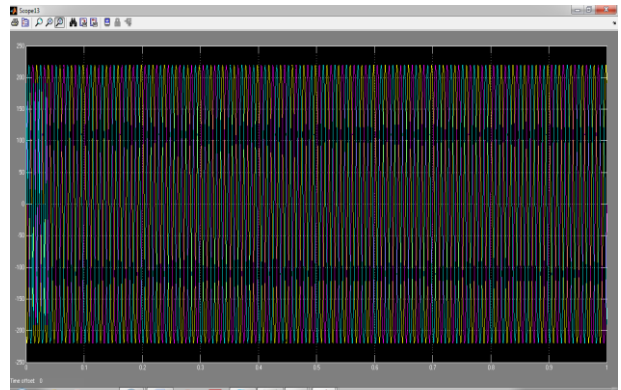

fig6: Three phase output Voltage with Matrix Converter

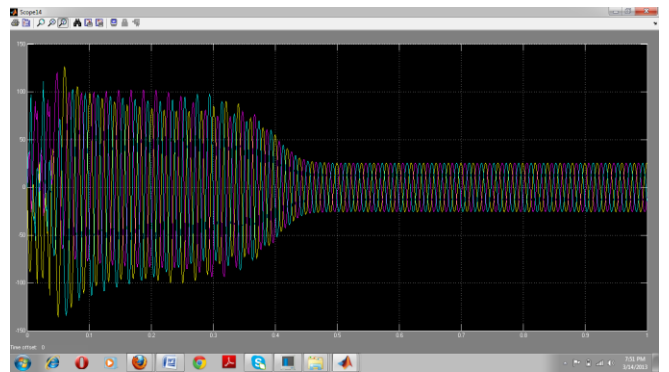

Fig7: Three phase output Current with Matrix Converter

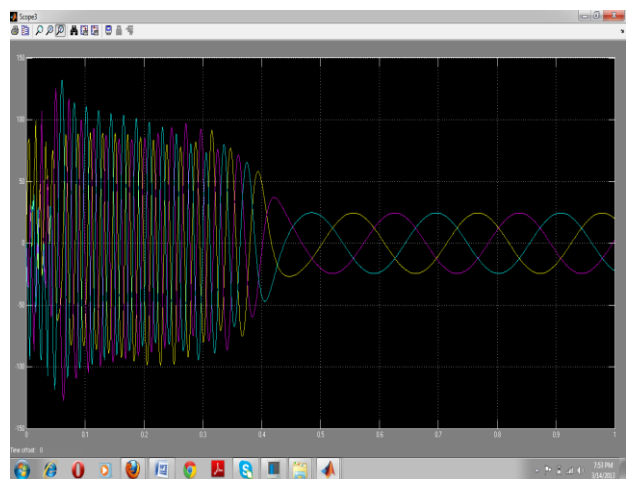

Fig8: Three phase Rotor current output

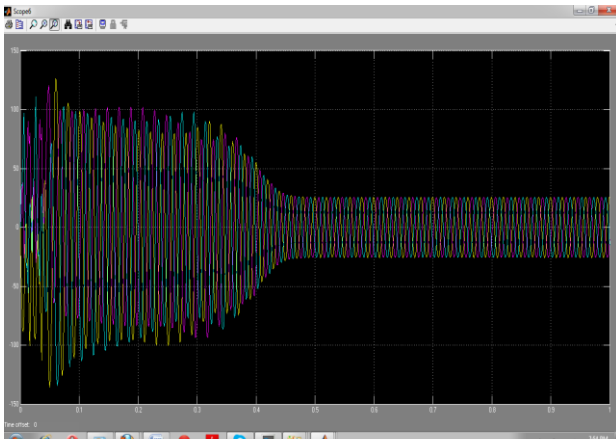

Fig9: Three phase Stator current output

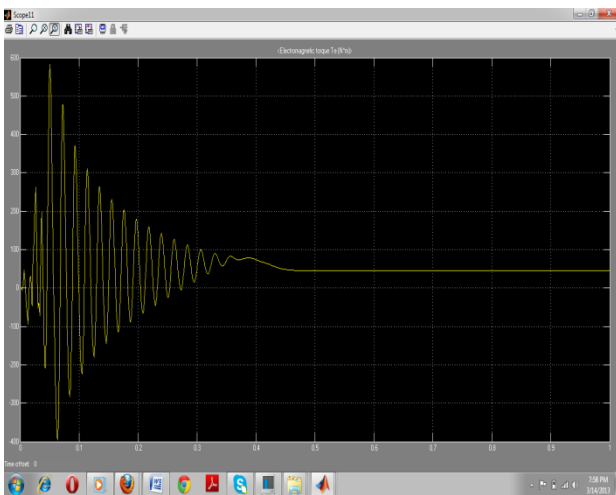

Fig10. Torque Response IM with MC

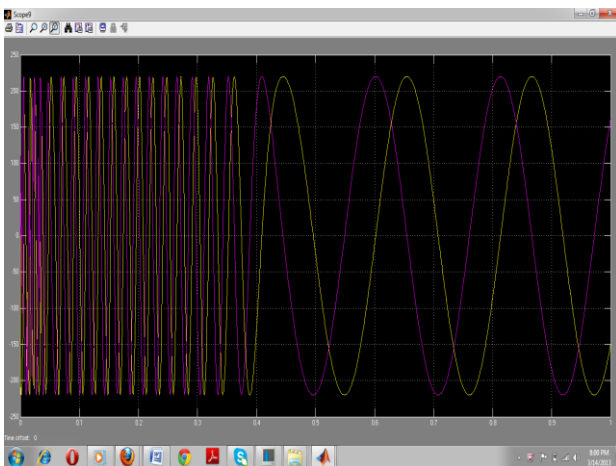

Fig11. Stator d-q Response for IM with MC.

This paper describes only actual outputs of the induction motor fed matrix Converter comparable

results with other AC-AC converters. The simulation parameters of induction motor is, Integrator type: ode45.

VIII. CONCLUSION

From the simulation results we conclude that the output voltage and input current of Matrix Converter is pure sinusoidal. Now, the induction motor is driven by using Matrix Converter certainly, the torque pulsating, and motor derating is reduced also the efficiency of the induction motor is increased. According to the literature [5]and[11], the induction motor is fed by VSI, CSI sources (non sinusoidal supplies)the harmonic losses[7] are produced in the machine. They cause significant reduction in motor efficiency and large increase in motor derating, torque pulsating. These limitations can be overcome by using matrix converter because of its unique feature is pure sinusoidal as output. A theoretical investigation was carried out and shown in simulation results. Therefore Matrix Converter is better alternative to the PWM inverters for driving electrical machines.

IX. REFERENCES

- [1] P.W.Wheeler, J.Rodriguez, J.C.Clare and L.Empringham, "Matrix converter –A technology review," IEEE Trans.Ind.Electron. vol.49, no.2, Apr. 2002,pp. 275 - 288.
- [2] Y Tatar and Sedat Sunter, "Pspice modeling and simulation of a matrix converter-fed induction motor drive,"Int.J.Eng Springer-Verlag, 2002, pp.295-301.
- [3] D.Casadei, G.Serra and A.Tani, "The use of matrix converters in direct torque of induction machines," IEEE Trans.Ind.Electron. vol.48, no.6, Dec. 2001,pp. 1057 - 1064.
- [4] Sedat Sunter and Tatar Y, "Pspice modeling and design of a snubber circuit for the matrix converter," Int.J.Eng Model 13, 2000,pp.41-46.
- [5] S.Williamson and Catherine I.McClay, "The effect of axial variations in saturation due to skew on induction motor equivalent circuit parameters," IEEE Trans.Ind.Applications, vol. 35, no.6, Nov/Dec. 1999,pp. 1323 – 1330.
- [6] C.L.Neft and C.D.Schauder, "Theory and design of a 30-Hp matrix converter," IEEE Trans.Ind.Applicat., vol.49, no.2, May/June. 1992,pp. 546 - 551.
- [7] G.K.Dubey, Power Semiconductor Controlled Drives, Prentice Hall, New Jersey: 1989, 495.
- [8] M.Imayavaramban, K.Latha and G.Uma, "Analysis of different schemes of matrix converter with maximum voltage conversion

- ratio,” in Proceedings of the 12th IEEE – MELECON, 2004.
- [9] J.W.Kolar and M.Baumann, “Novel three-phase AC-DC-AC sparse matrix converter,” in Proceedings of the 17th IEEE Applied Power Electronics Conference and Exposition, 2002, pp 777-790.
- [10] C.Klumpner, P.Nielsen, F.Blaabjerg, “Speeding-up maturation process of the matrix converter,” in Proceedings of the 32nd IEEE PESC, 2001, Canada, vol.2, pp.1083-1088.
- [11] B.Ozpineci and L.M.Tolbert, “Simulink implementation of induction machine model,” IEEE 0-7803-7817-2/03/, 2003, pp. 728 - 733

