

Decentralized load frequency controller analysis and tuning for multi-area power systems

Wen Tan*

School of Control and Computer Engineering, North China Electric Power University, Zhuxinzhuang, Dewai, Beijing 102206, PR China

ARTICLE INFO

Article history:

Received 23 July 2009

Received in revised form 25 March 2010

Accepted 13 December 2010

Keywords:

Load frequency control

Decentralized control

Multi-area power systems

PID controller

Robustness

ABSTRACT

Decentralized load frequency control (LFC) for multi-area power systems is studied in this paper. A method to analyze the stability of a multi-area power system under a decentralized LFC is derived by accounting the inherent structure of the multi-area power system. The method separates the local transfer matrix from the tie-line power flow network, and the impacts of the tie-line power flow network and the local load frequency controllers on the power system can be easily checked. This result makes it possible to tune the local LFC controller for each area by first ignoring the tie-line power flow network. Decentralized LFC tuning on a three-area and a four-area power system shows that the proposed method is easy to apply for multi-area power systems and good damping performance can be achieved.

© 2010 Elsevier Ltd. All rights reserved.

1. Introduction

Load frequency control (LFC) is a major function of automatic generation control (AGC) systems. Usually AGC is organized in three levels:

- Primary control is performed by the speed governors of the generating units, which provide immediate (automatic) action to sudden change of load (or change of frequency). With primary control, a variation in system frequency greater than the dead band of the speed governor will result in a change in unit power generation. Transients of primary control are in the time-scale of seconds.
- Secondary control restores frequency to its nominal value and maintains the power interchange among areas by adjusting the output of selected generators. Transients of secondary control are in the order of minutes.
- Tertiary control is an economic dispatch that is used to drive the system as economically as possible and restore security levels if necessary. Tertiary control is usually performed every 5 min.

The speed governor on each generating unit provides the primary speed control function, and all generating units contribute to the overall change in generation, irrespective of the location of the load change, using their speed governing. However, primary

control action is usually not sufficient to restore the system frequency, especially in an interconnected power system so the secondary control loop is required to adjust the load reference set point through the speed-changer motor. Secondary control is commonly referred to as load frequency control [1].

See [2,3] for a complete review of recent advance in LFC. LFC becomes more significant today with the increasing size and complexity of interconnected power systems. Multivariable control techniques can be used to design centralized load frequency controllers, however, due to the inherent structure of large-scale power systems, decentralized load frequency control is more appealing for its simplicity in design and implementation. [4] discussed robust decentralized load frequency control for power systems with parametric uncertainties based on the Riccati-equation approach; [5] studied automatic generation control problem in a four-area power system using layered artificial neural network (ANN) technique; [6] treated the decentralized load frequency control design as a decentralized controller design problem for a multi-input multi-output control system, and discussed local area LFC design using structured singular values method; [7] proposed a systematic approach to design sequential decentralized load frequency controllers based on μ synthesis technique; [8] proposed a decentralized adaptive load frequency control scheme to cope with changes in the parameters of power systems; and [9] studies a four-area power system using fuzzy logic controller.

Most of the methods suggest complex state-feedback or high-order dynamic controllers, which are not practical for industrial practices. Design of PI and PID-type load frequency controllers attracts attention in the past few years. Rerkpreedapong et al. [10]

* Tel.: +86 10 61772107; fax: +86 10 61772260.

E-mail address: wtan@ieee.org

Nomenclature

Δf_i incremental frequency deviation of Area #i (Hz)
 ΔP_{Gi} incremental change in generator output in Area #i (p.u. MW)
 ΔX_{Gi} incremental change in governor valve position in Area #i
 ΔP_{di} load disturbance in Area #i (p.u. MW)
 ΔP_{tiei} incremental change in tie-line power between Area #i and other areas (p.u. MW)

$G_{gi}(s)$ transfer function of the governor in Area #i
 $G_{ti}(s)$ transfer function of the turbine in Area #i
 $G_{pi}(s)$ transfer function of the generator in Area #i
 R_i droop characteristic for Area #i (Hz/p.u. MW)
 B_i the frequency bias setting of Area #i (p.u. MW/Hz)
 T_{ij} synchronizing coefficients between Area #i and #j (p.u. MW/Hz)

designed robust decentralized PI-type load frequency controller using genetic algorithms (GA) and linear matrix inequalities (LMI) methods, and [11] used an iterative LMI algorithm; [12] discussed load frequency control using fuzzy gain scheduling of PI controllers; and [13–15] considered various methods to optimize PID gains for a three-area power system. These methods greatly simplify the complexity of the load frequency controllers. However, they are not very flexible, since the design methods rely on the parameters and/or the structure of the power systems. If the parameters or the structure are changed, the controllers have to be re-designed and are not easy to re-tune. Recently, attention has been paid to the tuning of PID-type load frequency control. [16] proposed a tuning method for single-area power system, and the result is extended to two-area systems [17–19] proposed to tune PID load frequency controller via internal model control (IMC) technique. It was shown that with two tuning parameters the method can achieve good performance for power systems with non-reheated, reheated, and hydro turbines, and it can be extended to tune decentralized load frequency controller for multi-area power systems by assuming that there is no tie-line power flow among areas. The above idea for decentralized load frequency controller design and tuning will be further investigated in this paper, specifically, a method to analyze the stability of a multi-area power system under a decentralized LFC is proposed taking the inherent structure of the multi-area power system into consideration. This result makes it possible to easily check the impacts of the tie-line power flow network and the local load frequency controllers on the whole power system. Decentralized LFC tuning on a three-area and a four-area power system shows that the proposed method is easy to apply for multi-area power systems and good damping performance can be achieved.

$$u_i = -K_i(s)B_i\Delta f_i \tag{3}$$

Denote the transfer functions of the governor, the turbine and the generator for Area #i by $G_{gi}(s)$, $G_{ti}(s)$, and $G_{pi}(s)$, respectively, then the transfer function from Δf_i to u_i can be easily found as

$$G_i(s) = \frac{G_{gi}G_{ti}G_{pi}}{1 + G_{gi}G_{ti}G_{pi}/R_i} \tag{4}$$

So it is clear that to tune a decentralized load frequency controller, one just needs to tune PID controller for the following transfer function for Area #i.

$$P_i(s) = G_i(s)B_i \tag{5}$$

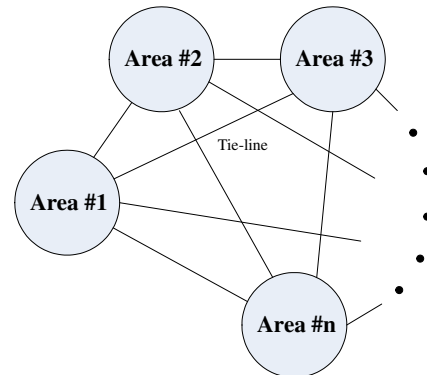

Fig. 1. Simplified diagram of a multi-area interconnected power system.

2. Decentralized load frequency control

Consider the load frequency control problem for a multi-area power system as shown in Fig. 1, and each area has the structure shown in Fig. 2.

The load frequency control problem requires that not only the frequency deviation of each area must return to its nominal value but also the tie-line power flows must return to their scheduled values. So a composite variable, the area control error (ACE), is used as the feedback variable to ensure the two objectives. For Area #i, the area control error is defined as

$$ACE_i = \Delta P_{tiei} + B_i\Delta f_i \tag{1}$$

The feedback control for Area #i takes the form

$$u_i = -K_i(s)ACE_i \tag{2}$$

A decentralized controller can be tuned assuming that there are no tie-line power flows, i.e., $\Delta P_{tiei} = 0$ ($i = 1, \dots, n$). In this case the local feedback control will be

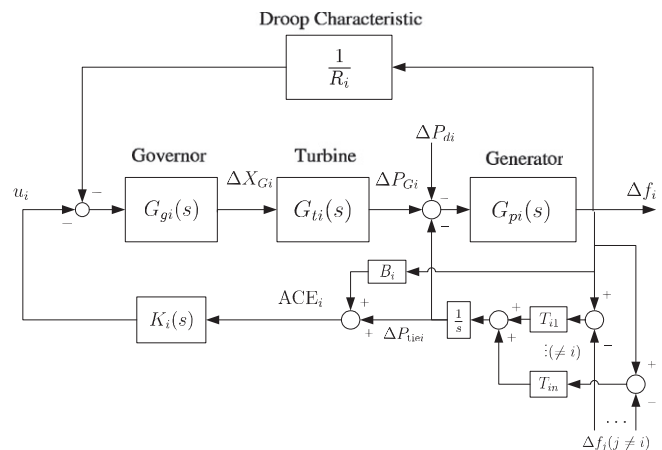

Fig. 2. Block diagram of control area i.

3. LFC-PID tuning via IMC

The difficulty in PID design and tuning for load frequency control lies in the fact that the power system model (5) is of high order and generally under-damped. Most of the existing PID tuning methods concentrate on over-damped processes, so direct application of existing PID tuning methods for LFC is not appropriate. Nevertheless, in [16,17], a PID load frequency controller tuning method was proposed based on the PID tuning method proposed in [20,18], it was shown that for LFC tuning purpose, the transfer function of the power systems can be approximated with a second-order oscillatory model, and a PID tuning procedure can be done based on a two-degree-of-freedom (TDF) internal model control (IMC) method. In [19] it is observed that the TDF-IMC design method can be directly applied to plant model (5) thus the approximation in [18] is not necessary, so the method is not only applicable to power systems with non-reheat turbines, but also to power systems with reheat and hydro turbines.

The IMC-PID tuning procedure goes as follows [18,19]:

- (i) Decompose the plant model $\tilde{P}(s)$ into two parts:

$$\tilde{P}(s) = P_M(s)P_A(s) \quad (6)$$

where $P_M(s)$ is the minimum-phase (invertible) part and $P_A(s)$ is the allpass (nonminimum-phase with unity magnitude) part.

- (ii) Design a setpoint-tracking IMC controller

$$Q(s) = P_M^{-1}(s) \frac{1}{(\lambda s + 1)^r} \quad (7)$$

where λ is a tuning parameter such that the desired setpoint response is $\frac{1}{(\lambda s + 1)^r}$, and r is the relative degree of $P_M(s)$.

- (iii) Design a disturbance-rejecting IMC controller of the form

$$Q_d(s) = \frac{\alpha_m s^m + \dots + \alpha_1 s + 1}{(\lambda_d s + 1)^m} \quad (8)$$

where λ_d is a tuning parameter for disturbance rejection, m is the number of poles of $\tilde{P}(s)$ such that the $Q_d(s)$ needs to cancel. Suppose p_1, \dots, p_m are the poles to be canceled, then $\alpha_1, \dots, \alpha_m$ should satisfy

$$(1 - \tilde{P}(s)Q(s)Q_d(s))|_{s=p_1, \dots, p_m} = 0 \quad (9)$$

- (iv) Transform it to a conventional unity feedback controller

$$K(s) = \frac{Q(s)Q_d(s)}{1 - \tilde{P}(s)Q(s)Q_d(s)} \quad (10)$$

- (v) Expand $K(s)$ into Maclaurin series to get the PID parameters, or approximate it in the frequency domain by the procedure proposed in [18,19].

The performance of the resulting PID controller is related to two tuning parameters which makes it flexible to re-tune when necessary. For load frequency control, we need to use Q_d to cancel the undesirable poles (e.g., oscillatory and/or unstable poles) of $P_i(s)$ (5) to achieve good disturbance rejection performance. MATLAB-based programs for general TDF-IMC design and PID reduction are available for such purpose.

4. Stability analysis of decentralized LFC

It is shown that the decentralized load frequency control of multi-area power systems requires tuning the local PID controller for the model (5). Each local PID can be tuned independently. However, since tie-line power flows among areas are ignored in the local load frequency control design, we need to check the stability of

the whole system to ensure the designed decentralized PID controller works after the local controllers have been tuned. Many multivariable stability theories can be applied to check the stability of a multi-area power system under a decentralized LFC controller. However, we note that the multi-area power system has its specific structure, so a simple method can be derived for the stability analysis.

For Area # i , it is easy to find the transfer function from the tie-line power flow deviation ΔP_{tiei} to the frequency deviation Δf_i by using the well-known Mason's rule as

$$\Delta f_i = -M_i(s)\Delta P_{tiei} \quad (11)$$

where $M_i(s)$ is given by

$$M_i(s) := \frac{G_{pi}(s) + G_{gi}(s)G_{ti}(s)G_{pi}(s)K_i(s)}{1 + G_{gi}(s)G_{ti}(s)G_{pi}(s)/R_i + G_{gi}(s)G_{ti}(s)G_{pi}(s)K_i(s)B_i} \quad (12)$$

Since the tie-line power flow equals

$$\Delta P_{tiei} = \sum_{j \neq i}^n \frac{T_{ij}}{s} (\Delta f_i - \Delta f_j) \quad (13)$$

then we have

$$\Delta f_i = -M_i(s) \sum_{j \neq i}^n \frac{T_{ij}}{s} (\Delta f_i - \Delta f_j), \quad i = 1, 2, \dots, n \quad (14)$$

Denote

$$\Delta f = [\Delta f_1, \dots, \Delta f_n]^T \quad (15)$$

and put (14) into the matrix form, we have

$$\Delta f = -M(s) \frac{T}{s} \Delta f \quad (16)$$

where the 'local transfer matrix' $M(s)$ is a diagonal matrix defined by

$$M(s) := \begin{bmatrix} M_1(s) & 0 & \dots & 0 \\ 0 & M_2(s) & \dots & 0 \\ \vdots & \vdots & \ddots & \vdots \\ 0 & 0 & \dots & M_n(s) \end{bmatrix} \quad (17)$$

and the 'tie-line network matrix' T is a constant matrix defined by

$$T := \begin{bmatrix} \sum_{j \neq 1}^n T_{1j} & -T_{12} & \dots & -T_{1n} \\ -T_{21} & \sum_{j \neq 2}^n T_{2j} & \dots & -T_{2n} \\ \vdots & \vdots & \ddots & \vdots \\ -T_{n1} & -T_{n2} & \dots & \sum_{j \neq n}^n T_{nj} \end{bmatrix} \quad (18)$$

It is not hard to verify that all the closed-loop transfer functions for the n -area power system with a decentralized LFC controller contains $(I + M(s)T/s)^{-1}$ as in (16), so we have:

Theorem 1. Given an n -area power system shown in Fig. 1 and assume that each area has the structure as shown in Fig. 2. Then the whole power system is stable if and only if the following transfer function is stable.

$$h(s) := \det(I + M(s)T/s) \quad (19)$$

It is observed that the local transfer matrix $M(s)$ and the tie-line power flow network T are separated from each other in $h(s)$ due to the inherent structure of the multi-area power systems, so it is easy to check the effects of local controllers ($M(s)$) and the tie-line interconnection network (T) on the stability of the whole power system.

For example, consider the two-area case, we have

$$T = \begin{bmatrix} T_{12} & -T_{12} \\ -T_{21} & T_{21} \end{bmatrix} \quad (20)$$

Suppose $T_{12} = T_{21} = \gamma$, then

$$T = \begin{bmatrix} \gamma & -\gamma \\ -\gamma & \gamma \end{bmatrix} = \gamma \begin{bmatrix} 1 & -1 \\ -1 & 1 \end{bmatrix} \quad (21)$$

Since $\det(I + AB) = \det(I + BA)$ for any compatible matrices A and B , we have

$$h(s) = \det(I + MT/s) = 1 + \tilde{M}(s)\gamma/s \quad (22)$$

where

$$\tilde{M}(s) = [1 \quad -1] \begin{bmatrix} M_1(s) & 0 \\ 0 & M_2(s) \end{bmatrix} \begin{bmatrix} 1 \\ -1 \end{bmatrix} = M_1(s) + M_2(s) \quad (23)$$

So the maximum γ such that the power system remains stable is the largest gain which destabilizes $\tilde{M}(s)/s$. It can be checked by using the root locus of $\tilde{M}(s)/s$. The procedure is discussed in detail in [18].

For interconnected power systems with more than two areas, the tie-line power flow network T is much more complicated and the stability of the whole power system relies on the structure of the tie-line network, the magnitude of each tie-line flow, and the local load frequency controllers. Checking the roots of $h(s)$ under different tie-line network structure and magnitude can verify the performance of the designed decentralized LFC.

In summary, the decentralized load frequency controller for a multi-area power system can be tuned by first assuming that the tie-line power flow is zero and tune the local PID controller for model (5) using the IMC-PID method by carefully choosing the two tuning parameters λ_i and λ_{di} ($i = 1, \dots, n$). After that, check the minimal damping ratio of $h(s)$ (19) to ensure the tuned decentralized LFC has a desired damping performance. If not, detune the local PID controller by re-selecting λ_i and λ_{di} .

5. Illustrative examples

Two examples are considered in this section to illustrate the proposed method.

5.1. A three-area power system

Consider a three-area power system discussed in [4]. The transfer functions for the power systems are:

$$G_{gi} = \frac{1}{T_{Gi}s + 1}, \quad G_{ti} = \frac{1}{T_{Ti}s + 1}, \quad G_{pi} = \frac{K_{pi}}{T_{pi}s + 1}, \quad (i = 1, 2, 3) \quad (24)$$

with

$$\begin{aligned} T_{G1} &= 0.08, \quad T_{T1} = 0.3, \quad T_{P1} = 20; \quad K_{P1} = 120, \quad R_1 = 2.4 \\ T_{G2} &= 0.072, \quad T_{T2} = 0.33, \quad T_{P2} = 25; \quad K_{P2} = 112.5, \quad R_2 = 2.7 \\ T_{G3} &= 0.07, \quad T_{T3} = 0.35, \quad T_{P3} = 20; \quad K_{P3} = 115, \quad R_3 = 2.5 \end{aligned} \quad (25)$$

The frequency bias settings are $B_i = 0.4$ ($i = 1, 2, 3$) and the synchronizing coefficients are

$$T_{12} = T_{13} = T_{21} = T_{23} = T_{31} = T_{32} = 0.5 \quad (26)$$

Adopting IMC-PID tuning procedure discussed in Section 3 and choose $\lambda = 0.04$, $\lambda_d = 0.4$ for each area, we have the local PID controllers

$$\begin{aligned} K_1(s) &= 4.8279 + \frac{6.3387}{s} + 1.4448s \\ K_2(s) &= 7.4252 + \frac{9.0186}{s} + 2.0507s \\ K_3(s) &= 5.8979 + \frac{7.4629}{s} + 1.7059s \end{aligned} \quad (27)$$

The roots of $h(s)$ for the current tie-line network all lies on the left-hand plane so the designed decentralized system is stable. In fact, the minimal damping ratio of all the roots is about 0.295, so the performance of the designed decentralized system is good enough.

To show the performance of the decentralized PID controller, a step load $\Delta P_{d1} = 0.01$ is applied to Area #1 at $t = 1$, followed by a step load $\Delta P_{d2} = 0.01$ at Area #2 and a step load $\Delta P_{d3} = 0.01$ at Area #3. The responses of the power system are shown in Figs. 3 and 4. Also shown are the responses of the decentralized state-feedback controller designed in [4]. It is observed that the proposed decentralized PID controller achieves better damping for frequency and tie-line power flow deviations in all the three-areas.

The power systems may be subjected to uncertainties in the parameters due to parameter estimation errors or operating point changes. So a detailed robustness analysis against the uncertainties should be performed to ensure that the designed system is robust. For single-area power system, the procedure is detailed in [21,18]. For multi-area power systems, the procedure is difficult to apply since the number of uncertainties in the structure and in the parameters is large. However, robustness analysis for each area may help understand the robustness of the whole system. Anyway, if the local controller is not robust against parameter uncertainties in its area, it is hardly robust against parameter uncertainties from other areas. The singular value singular (SSV) plots against 50% uncertainties in the five parameters (T_G , T_T , T_P , K_P , and R) for each area are shown in Fig. 5. Since the maximum of each structured singular value is less than 1, so each local PID controller can guarantee 50% uncertainties in all the five parameters in each area.

The responses of the system when the parameters of each area are changed by 50% under the current tie-line network are shown in Fig. 6. It clearly verifies the statement above. The decentralized controller designed in [4] cannot guarantee system stability when all the parameters are at their upper bounds, so its responses are not shown here.

Now that the designed decentralized controller are robust against parameter variations in each area. Is it robust against tie-line power flow network? Using Theorem 1, it is easy to verify that the largest T_{ij} such that the decentralized system becomes unstable under current tie-line structure is about 1.62, while currently T_{ij} is 0.5, thus the tuned decentralized PID controller is quite robust against tie-line operation. To verify this, suppose the synchronizing coefficients are increased by 100%, the responses of the power

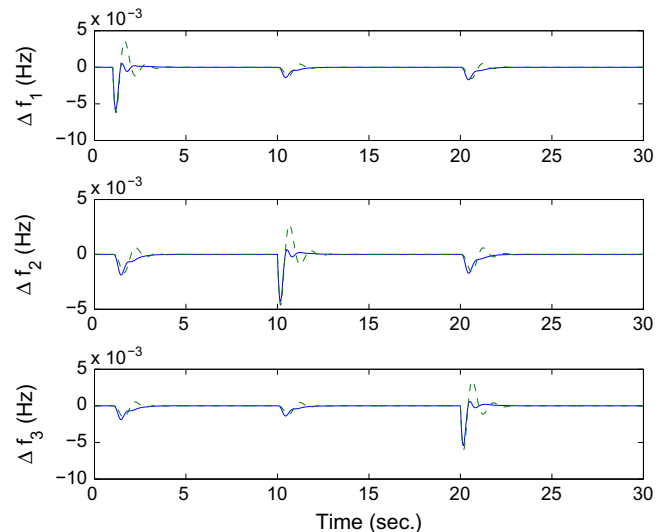

Fig. 3. Responses of the three-area power system: Δf (solid: proposed; dashed: [4]).

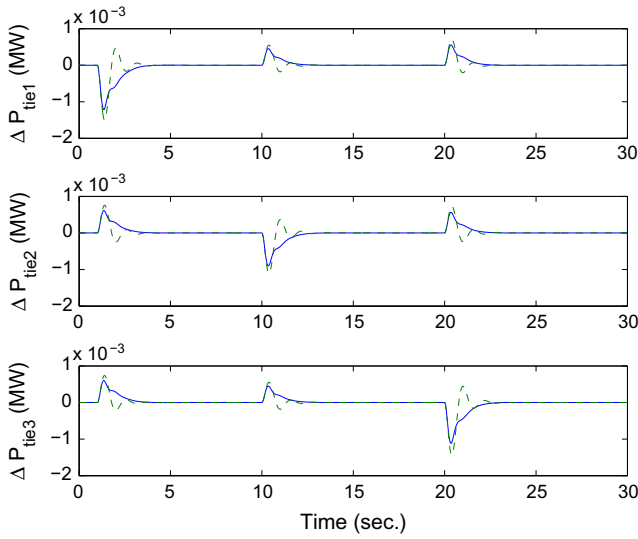

Fig. 4. Responses of the three-area power system: ΔP_{tie} (solid: proposed; dashed: [4]).

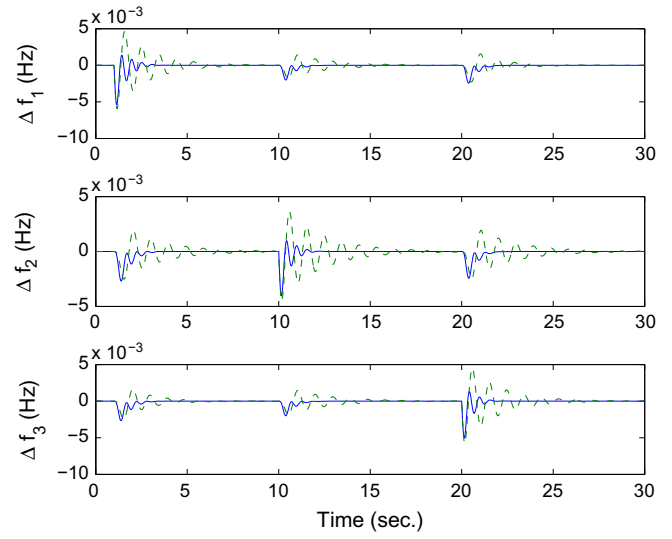

Fig. 7. Responses of the three-area power system under tie-line uncertainty (solid: proposed; dashed: [4]).

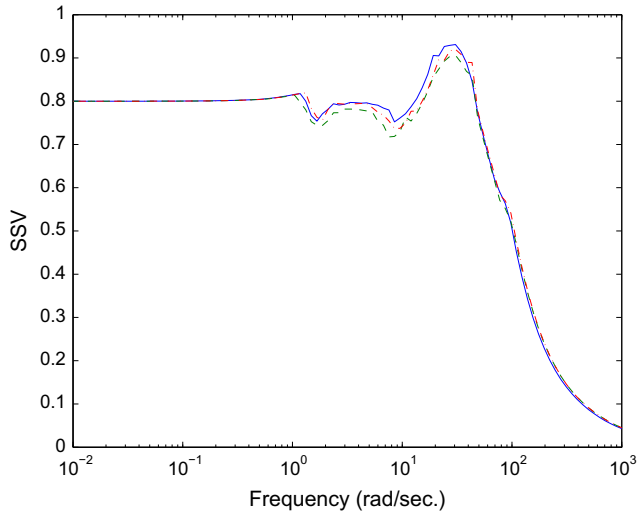

Fig. 5. Structured singular values for parameter variations in each area (solid: Area #1; dashed: Area #2; dashdotted: Area #3).

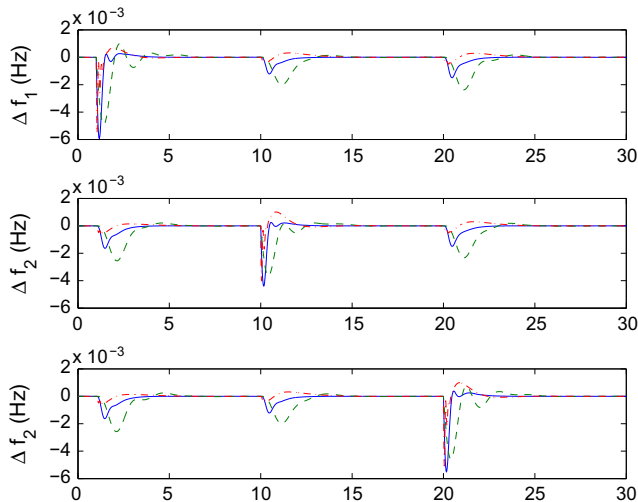

Fig. 6. Responses of the three-area power system under parameter uncertainties in all areas (solid: nominal; dashed: upper bound; dashdotted: lower bound).

system are shown in Fig. 7. The proposed decentralized LFC shows better performance than the one designed in [4].

Another issue not considered in the decentralized LFC tuning procedure is the generation rate constraint (GRC), which would influence the dynamic responses of power systems significantly. If the generation rate constraint (GRC) is 0.0017 MW/s for each area, the power system will be unstable with the proposed decentralized LFC controller. However, if the anti-GRC scheme proposed in [18] is used, the power system will be stable. Fig. 8 shows the responses of the system when there are load disturbances of magnitude 0.01 simultaneously at the three-areas at $t = 1$. The parameter k_c (Fig. 8 in [18]) in the anti-GRC scheme is chosen as 1 for each area. The effectiveness of the anti-GRC scheme is clear. When there are uncertainties in the parameters of each area and the tie-line power flow magnitude, the anti-scheme still works well. For brevity, the figures are not shown here.

5.2. A four-area power system

Consider a four-area power system discussed in [6]. The simplified diagram of the power system is shown in Fig. 9. Area #1, #2 and #3 are interconnected with each other, but Area #4 is only connected with Area #1.

The transfer functions for the power systems are:

$$G_{gi} = \frac{1}{T_{Gi}S + 1}, \quad G_{ti} = \frac{1}{T_{Ti}S + 1}, \quad G_{pi} = \frac{K_{pi}}{T_{pi}S + 1}, \quad (i = 1, 2, 3, 4) \quad (28)$$

with

$$\begin{aligned} T_{G1} &= 0.08, \quad T_{T1} = 0.3, \quad T_{P1} = 20; \quad K_{P1} = 120, \quad R_1 = 2.4, \\ T_{G2} &= 0.072, \quad T_{T2} = 0.33, \quad T_{P2} = 25; \quad K_{P2} = 112.5, \quad R_2 = 2.7, \quad (29) \\ T_{G3} &= 0.07, \quad T_{T3} = 0.35, \quad T_{P3} = 20; \quad K_{P3} = 125, \quad R_3 = 2.5, \\ T_{G4} &= 0.085, \quad T_{T4} = 0.375, \quad T_{P1} = 15; \quad K_{P4} = 115, \quad R_4 = 2.0 \end{aligned}$$

The frequency bias settings are $B_i = 0.425$ ($i = 1, \dots, 4$) and the synchronizing coefficients are

$$\begin{aligned} T_{12} &= T_{13} = T_{21} = T_{23} = T_{31} = T_{32} = T_{14} = T_{41} = 0.545, \\ T_{24} &= T_{42} = T_{34} = T_{43} = 0. \end{aligned} \quad (30)$$

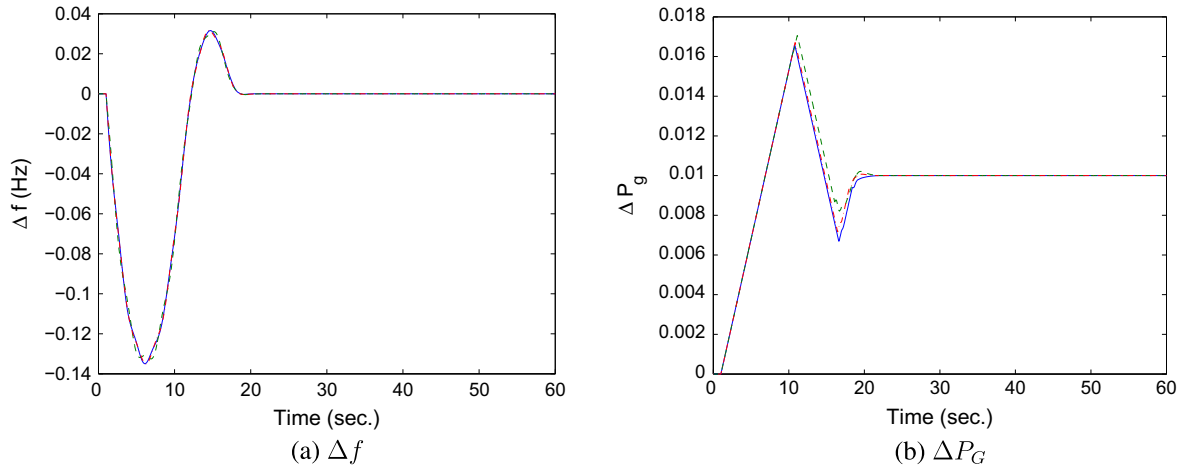

Fig. 8. Responses of the three-area power system with GRC (solid: Area #1; dashed: Area #2; dashdotted: Area #3).

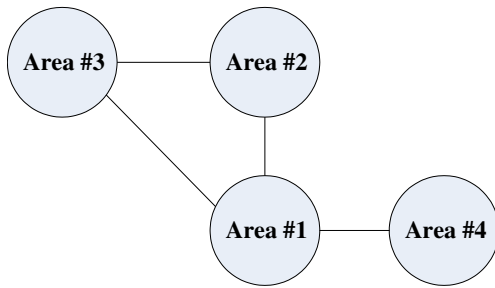

Fig. 9. Simplified diagram of a four-area power system.

Adopting IMC-PID tuning procedure discussed in Section 3 and choose $\lambda = 0.1$, $\lambda_d = 0.6$ for each area, we have the local PID controllers

$$\begin{aligned}
 K_1(s) &= 0.6553 + \frac{1.1028}{s} + 0.3902s \\
 K_2(s) &= 1.4516 + \frac{1.5600}{s} + 0.5749s \\
 K_3(s) &= 0.8084 + \frac{1.1771}{s} + 0.4478s \\
 K_4(s) &= 0.3449 + \frac{1.0256}{s} + 0.4298s
 \end{aligned} \tag{31}$$

The roots of $h(s)$ for the current tie-line network all lies on the left-hand plane so the designed decentralized system is stable. In fact, the minimal damping ratio of all the roots is about 0.1968, so the performance of the designed decentralized system is good.

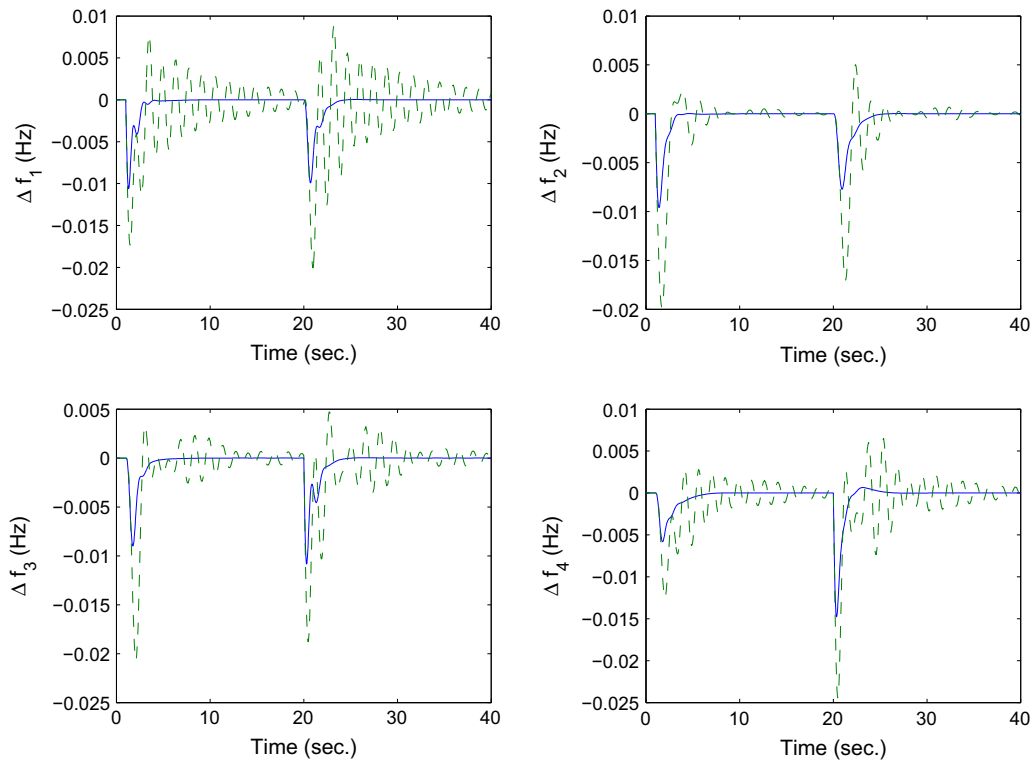

Fig. 10. Responses of the four-area power system: Δf (solid: proposed; dashed: [6]).

To show the performance of the decentralized PID controller, step loads $\Delta P_{d1} = \Delta P_{d2} = 0.01$ are applied simultaneously at Areas #1 and #2 at $t = 1$ and followed by step loads $\Delta P_{d3} = \Delta P_{d4} = 0.01$ simultaneously at Areas #3 and #4. The responses of the system are shown in Figs. 10 and 11. Also shown are the responses of the decentralized state-feedback controller designed in [6]. It is

observed that the proposed decentralized PID controller achieves better damping for frequency and tie-line power flow deviations in all the four areas.

It is easy to verify that the designed LFC is robust against uncertainties in the parameters of each area as in the previous example. For brevity the figures are omitted here. Using theorem 1, it is easy

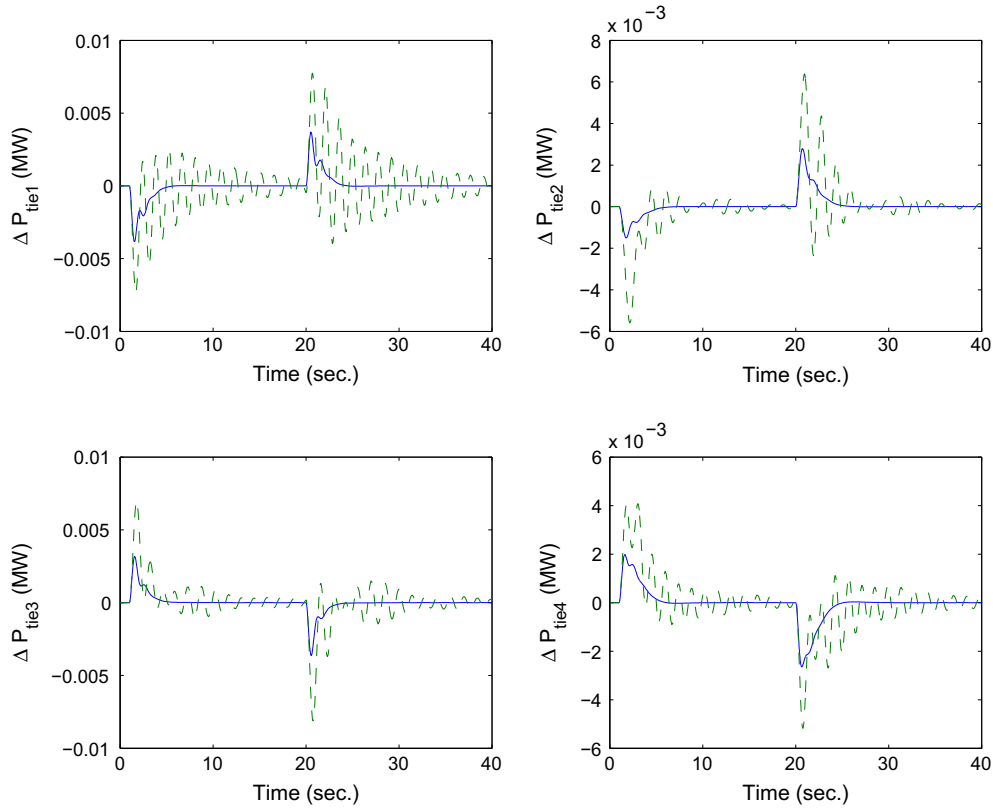

Fig. 11. Responses of the four-area power system: ΔP_{tie} (solid: proposed; dashed: [6]).

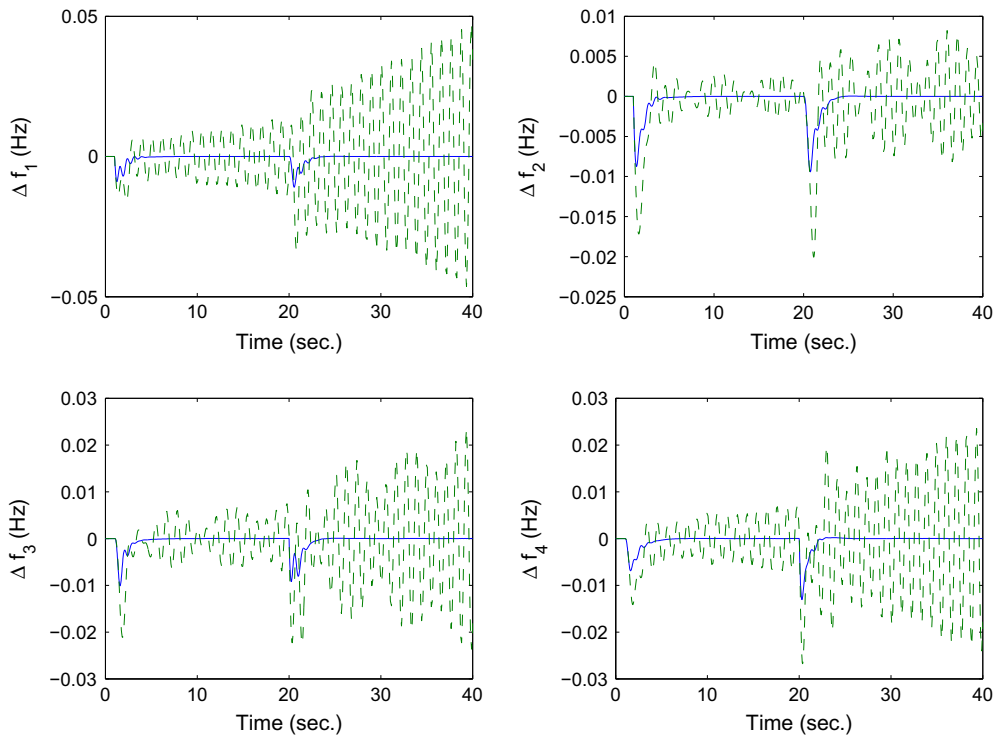

Fig. 12. Responses of the four-area power system under magnitude variation in the tie-line network (solid: proposed; dashed: [6]).

to verify that the largest T_{ij} such that the decentralized system becomes unstable under current tie-lie structure is about 1.64, while currently T_{ij} is 0.545, thus the tuned decentralized PID controller is

quite robust against tie-line operation. To verify this, suppose the synchronizing coefficients are increased by 100%, the responses of the power system are shown in Fig. 12. The proposed decentral-

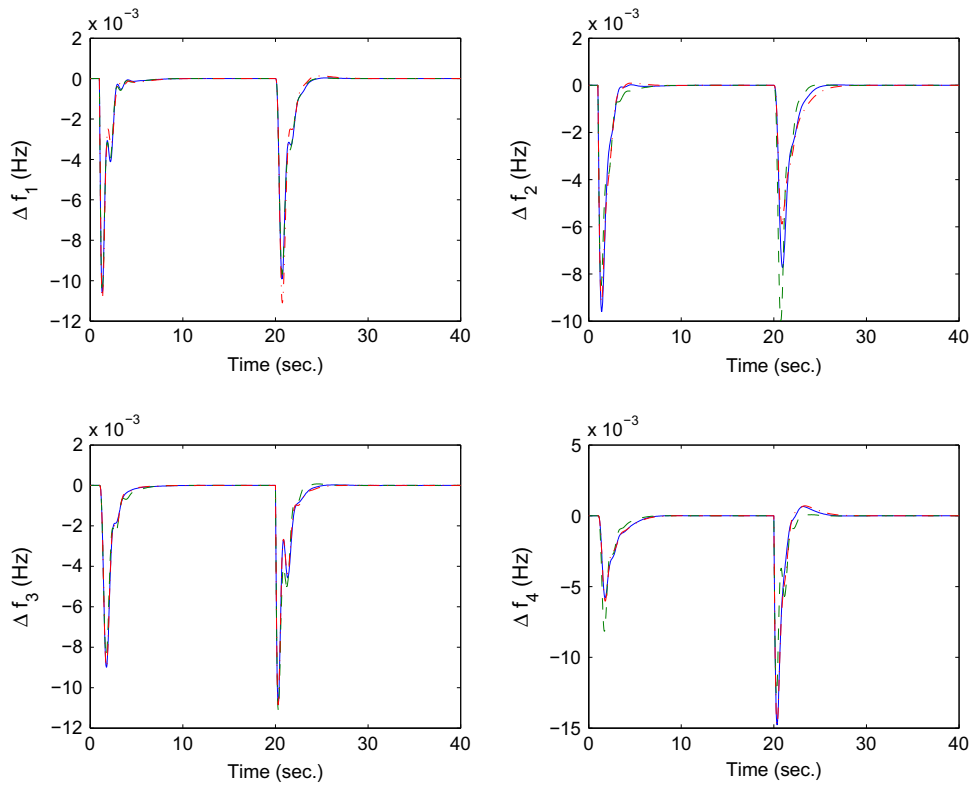

Fig. 13. Responses of the four-area power system under structure variation in the tie-line network: Δf (solid: current; dashed: Case 1; dashdotted: Case 2).

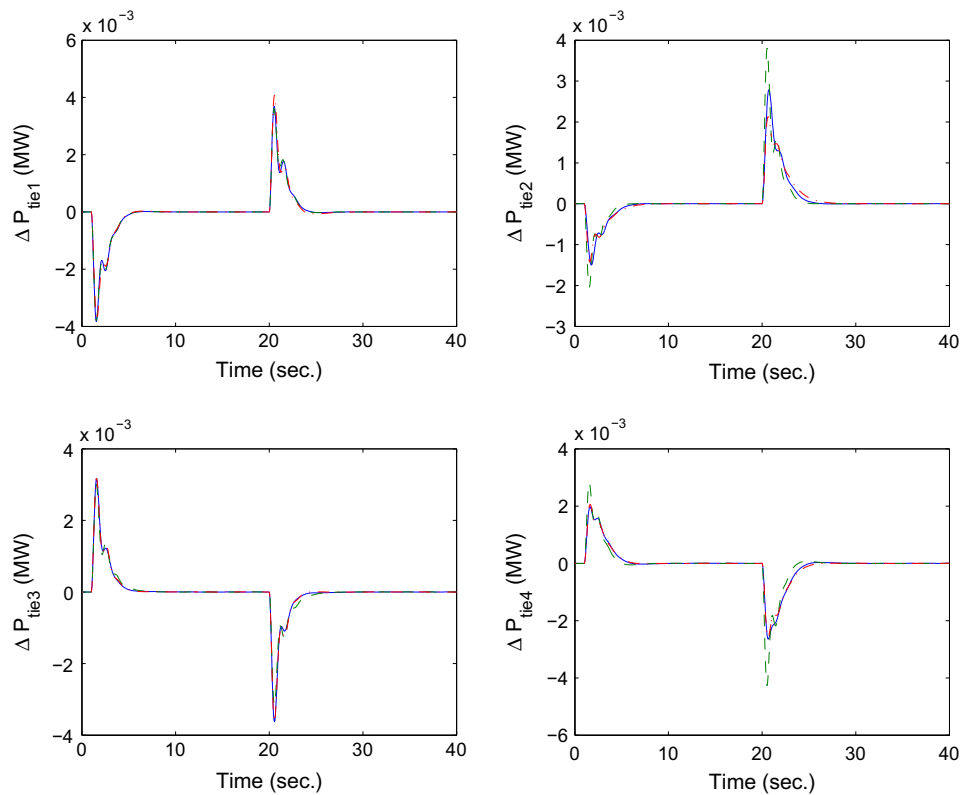

Fig. 14. Responses of the four-area power system under structure variation in the tie-line network: ΔP_{tie} (solid: current; dashed: Case 1; dashdotted: Case 2).

ized LFC shows acceptable damping (with minimal damping ratio of $h(s)$ equals 0.065), while the decentralized controller designed in [4] no longer stabilizes the power system.

Despite the possible magnitude change of the tie-line power flow network, its structure may also be changed. We consider two circumstances under the current network structure:

Case 1. Area #4 is connected to Area #2 and #3 ($T_{24} = T_{42} = T_{34} = T_{43} = 0.545$);

Case 2. Area #2 is disconnected from Area #1 ($T_{12} = T_{21} = 0$).

The system responses under the same load disturbances as before are shown in Figs. 13 and 14. It is observed that the designed decentralized LFC works well in the two cases. In fact, the minimal damping ratio of $h(s)$ is 0.181 for Case 1 and 0.231 for Case 2, which means that disconnecting one area from an existing power network may increase the damping of the system, while connecting more areas into an existing power network may decrease the damping of the system. However, the conclusion is only drawn from this example and may not be applicable to general multi-area systems.

6. Conclusion

Decentralized load frequency controller analysis and tuning were investigated in this paper. The local load frequency controllers were tuned by a two-degree-of-freedom IMC method by first ignoring the tie-line operation, and the stability of the multi-area power system under the decentralized LFC could be checked using a simple method. Design practice on a three-area and a four-area power system showed that the proposed method was easy to apply for multi-area power systems and could achieve good damping performance. Further research on checking the robustness of multi-area systems and on decentralized PID tuning considering the tie-line power flow network is under progress.

Acknowledgments

This work was supported by National Natural Science Foundation of China under Grant 60774012 and Beijing Natural Science Foundation under Grant 4092038.

References

- [1] Kundur P. Power system stability and control. McGraw-Hill; 1994.
- [2] Ibrabeem PK, Kothari DP. Recent philosophies of automatic generation control strategies in power systems. IEEE Trans Power Syst 2005;20(1):346–57.
- [3] Shayeghi H, Shayanfar HA, Jalili A. Load frequency control strategies: a state-of-the-art survey for the researcher. Energy Convers Manage 2009;50(2):344–53.
- [4] Lim KY, Wang Y, Zhou R. Robust decentralized load-frequency control of multi-area power systems. IEE Proc Part C 1996;143:377–86.
- [5] Zeynelgil HL, Demiroren A, Sengor NS. The application of ANN technique to automatic generation control for multi-area power system. Int J Elect Power Energy Syst 2002;24:345–54.
- [6] Yang TC, Ding ZT, Yu H. Decentralized power system load-frequency control beyond the limit of diagonal dominance. Int J Elect Power Energy Syst 2002;24(3):173–84.
- [7] Bevrani H, Mitani Y, Tsuji K. Sequential design of decentralized load frequency controllers using μ synthesis and analysis. Energy Convers Manage 2004;45:865–81.
- [8] Zribi M, Al-Rashed M, Alrifai M. Adaptive decentralized load frequency control of multi-area power systems. Int J Elect Power Energy Syst 2005;27:575–83.
- [9] Subbaraj P, Manickavasagam K. Automatic generation control of multi-area power system using fuzzy controller. Eur Trans Elect Power 2008;18:266–80.
- [10] Rerkpreedapong D, Hasanovic A, Feliachi A. Robust load frequency control using genetic algorithms and linear matrix inequalities. IEEE Trans Power Syst 2003;18(2):855–61.
- [11] Bevrani H, Mitani Y, Tsuji K. Robust decentralized load-frequency control using an iterative linear matrix inequalities algorithm. IEE Proc Gener Transm Distrib 2004;151(3):347–54.
- [12] Chang CS, Fu WH. Area load frequency control using fuzzy gain scheduling of PI controllers. Elect Power Syst Res 1997;42(2):145–52.
- [13] Ghoshal SP, Goswami SK. Application of GA based optimal integral gains in fuzzy based active power-frequency control of non-reheat and reheat thermal generating systems. Elect Power Syst Res 2003;67:79–88.
- [14] Ghoshal SP. Application of GA/GA-SA based fuzzy automatic generation control of a multi-area thermal generating system. Elect Power Syst Res 2004;70:115–27.
- [15] Ghoshal SP. Optimization of PID gains by particle swarm optimizations in fuzzy based automatic generation control. Elect Power Syst Res 2004;72:203–12.
- [16] A. Khodabakhshian, N. Golbon, Unified PID design for load frequency control. In: Proc 2004 IEEE int conf on control applications (CCA), Taipei, Taiwan; 2004. p. 1627–32.
- [17] Khodabakhshian A, Edrisi M. A new robust PID load frequency controller. Control Eng Pract 2008;16:1069–80.
- [18] Tan W. Tuning of PID load frequency controller for power systems. Energy Convers Manage 2009;50(6):1465–72.
- [19] Tan W. Unified tuning of PID load frequency controller for power systems via IMC. IEEE Trans Power Syst 2010;25(1):341–50.
- [20] Poulin E, Pomerleau A. PID tuning for integrating and unstable processes. IEE Proc Control Theory Appl 1996;143(5):429–34.
- [21] Tan W, Xu Z. Robust analysis and design of load frequency controller for power systems. Elect Power Syst Res 2009;79(5):846–53.