

Simulation of Resistive Super Conducting Fault Current Limiter and its Performance Analysis in Three Phase Systems

A. Rama Devi^{*}, J. Nani Kumar^{**}

^{*}Professor, Department of Electrical and Electronics Engineering, V.R.Siddhartha Engineering College, Vijayawada, India .

^{**}M.Tech Student, Department of Electrical and Electronics Engineering, V.R.Siddhartha Engineering College, Vijayawada, India.

ABSTRACT: -

This paper presents a resistive type superconducting fault current limiter to reduce the fault current effectively. As the consumption area of electric power is very wide, the chances of occurrence of any kind of fault or abnormal condition is very common, due to which a very high current flows through the system. These fault currents generate large mechanical forces which endanger the mechanical integrity of the power system hardware, transformers and other equipment may overheat. As the equipment in the power networks is very expensive, their protection from large fault currents is needed. The reliability of the power systems is the most important factor for their efficient operation. It is not possible to completely eliminate the faults in the system but it is possible to lower the harmful effects of fault on the systems by decreasing the current during fault. To overcome this problem a resistive superconducting fault current limiter (SFCL) is introduced. Super Conducting Fault Current Limiter is an innovative electric equipment which has the capability to reduce fault current level within the first cycle of fault current. The first cycle suppression of fault current by a SFCL results in an increased transient stability of the power system carrying higher power with greater stability.

Keywords – Fault Current Limitation, Superconducting Fault Current Limiter (SFCL), Resistive SFCL – Matlab Simulink.

1. Introduction: –

In today's world, electrical energy is unquestionably the most versatile and universally useful form of energy available. With increasing load, consumption of electrical energy is increased. As a result there is increase in the size of the generating station and the interconnected networks called power grids. Due to increase in the size of the grids and generating stations this also increases the possibility

of abnormal operation in the systems. There may be sudden decreases in the impedance of the power systems network, which lead to an increase in current, known as fault current, and faults in the electrical power systems are inevitable.

Conventional protection devices installed for protection of power system from the large fault currents especially at the high voltage substation level, are the circuit breakers tripped by over-current protection relay which has a response time delay that allows initial two or three fault current cycles to pass through before getting activated.

Superconducting fault current limiter (SFCL) is innovative electric equipment which has the capability to reduce fault current level within the first cycle of fault current. The first-cycle suppression of fault current by a SFCL results in an increased transient stability of the power system carrying higher power with greater stability.

The most important physical property dominating the current limiting behaviour of the SFCL is the electric field current density characteristics of High Temperature Superconductors (HTS) which is dependent on temperatures. Real time circuit current is as an input signal to the SFCL model and the output of the model is controlled by an advanced controlled time dependent resistance. In this paper, a SFCL model is intended using Matlab Simulink.

2. Superconducting Fault Current Limiter: –

An SFCL has virtually zero resistance at normal operating conditions. But in the occasion of a short circuit, due to the increasing temperature of the SFCL, the shift from the superconducting state to normal operating state which offers maximum preferred impedance to electric network instantaneously, which limits the current more rapid and effective way.

SFCL is an electronic device based on the principle of superconductivity. The current limiting behaviour depends on their nonlinear response to current,

temperature and magnetic field variations. These parameters cause a transition between normal conducting state to the superconducting state.

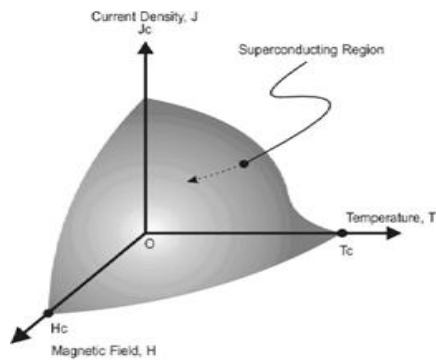

Fig: 1 T-B-J characteristics of superconductor material

The qualifications of SFCL are:

1. Very low impedance during normal operation. The current limiter must be “invisible” in this mode. Some transients such as those caused during the switching of a transformer should not inadvertently cause a transition of the limiter.
2. High impedance system during short-circuit. The limiter must perform its function in the case of massive short circuit but also in the case of low short-circuit fault.
3. Very good dynamic.
4. The system must transit in very quickly (within millisecond) to effectively limit the value of the short circuit.

The SFCL that we are concerned with is the resistive type. The current density of the superconductor would exceed the critical current density J_c when there is a fault. Fig: 1 Shows the Temperature, Magnetic Field and Current Density (T-B-J) characteristics of the superconductor material. It can be seen that the superconductor material can operate broadly in two states namely Superconducting state, and Normal conducting state. The innermost surface is the Superconducting state or Zero resistance state. It is observed that with increase in the current density, there is increase in temperature and magnetic flux density, the superconductor quickly changes to a high resistance state and the fault current is limited to a low value.

The impedance of the SFCL according to time t is specified by (1). Where R_m is the maximum resistance of the SFCL. TSC is the time constant. T_0 indicates the time to start the quenching. t_1 and t_2 indicates the first and second recovery times. It is clear that at normal operating conditions the impedance of SFCL is zero. But when fault

occurs, then the impedance goes to its peak value. After the recovery of fault it again comes to zero resistance.

$$R_{SFCL} = \begin{cases} 0 & (t_0 > t) \\ R_m [1 - \exp(-\frac{t-t_0}{TSC})]^{\frac{1}{2}} & (t_0 \leq t < t_1) \\ a_1(t-t_1) + b_1 & (t_1 \leq t < t_2) \\ a_2(t-t_2) + b_2 & (t_2 \leq t) \end{cases}$$

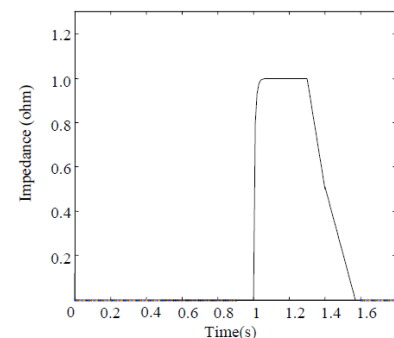

Fig: 2 Quench and recovery characteristics of SFCL

Fig: 2 interprets quenching and recovery characteristics of the SFCL derived from eq. (1). It is clear from Fig. 1 that at normal operating condition impedance of SFCL is zero. But when fault takes place at $t=1s$, quenching progression starts and then impedance goes to its peak value. After recovery of fault impedance again goes back to zero.

3. Simulation Model: –

Matlab/ Simulink/ SimpowerSystem was selected to design and implement the Resistive SFCL model. To design this Resistive type SFCL, four fundamental parameters are used. These parameters are given below.

1. Transition or Response time
2. Minimum Impedance & Maximum Impedance
3. Triggering Current
4. Recovery time

To determine the minimum or maximum impedance to output switch block is used. In Fig: 4 simulation model of SFCL is shown. Here the RMS value of the incoming current is calculated using RMS block. To reduce harmonics, first order filter is used. The developed SFCL model in Simulink/SimPowersystem works as follows: At first, the model measures the RMS value of the current passing in the system. Then, with the result of comparison between the current and the characteristics table shown in Fig: 3, the model decides whether the impedance level of SFCL goes maximum or minimum.

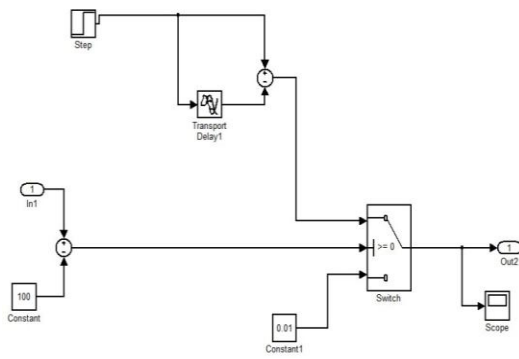

Fig: 3 Resistive SFCL characteristics table

SFCL’s resistance remains minimum, if the passing current is below the triggering current level; on the other hand, if current exceeds triggering current its resistance reaches to the maximum impedance level. A controlled voltage source is connected in order to compensate the voltage sag caused due to the induced fault current which is caused due to both internal and external causes.

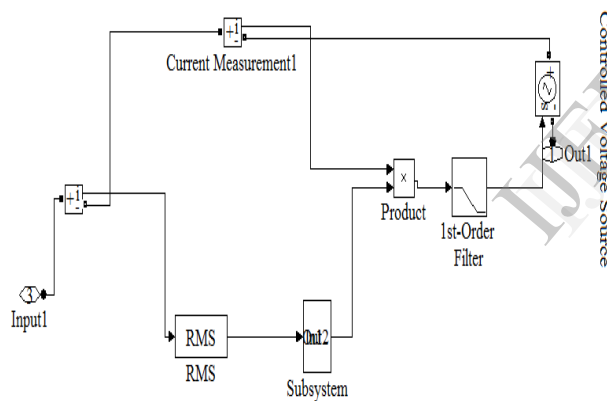

Fig: 4 SFCL model in Simulink

As a result, the increased impedance limits the short circuit fault current. However, SFCL’s resistance again goes minimum when current is lower than triggering current level.

Here a typical three phase system is designed using Simulink/SimPowerSystem which is given in Fig:5. Here a three phase source is taken as source and in between source and load the SFCL is placed. The system is taken under five types of faults (with and without using SFCL) which are: Line to Ground fault, Line to Line fault, Double Line to Ground fault, Three phase symmetrical fault, Three phase to Ground fault.

Table: 1 Parameter values of the proposed power system

Parameters	Value
AC Voltage (Vabc)	1732 V (RMS) (Per Phase)
Source Resistance	0.001 Ohms
Transmission Line Resistance	1 Ohm
Load Resistance	50 Ohms

A fault block is used to introduce these faults which is shown in Fig. 5. Then SFCL is added in the system for same condition.

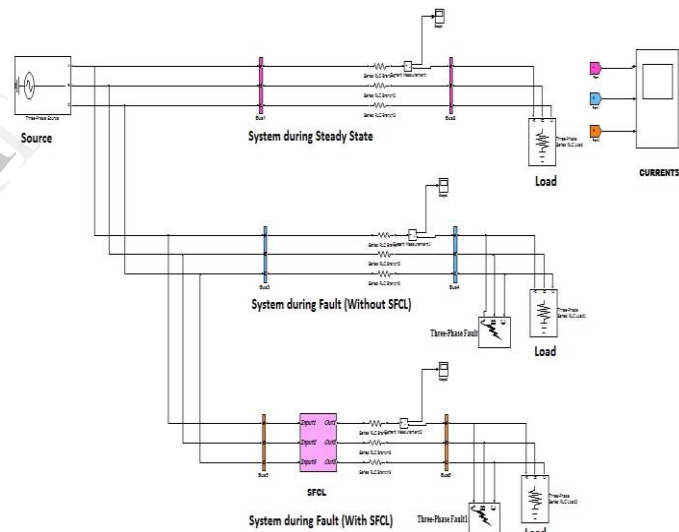

Fig: 5 Three phase system at steady state, during fault without SFCL and during fault with SFCL

4. Results And Discussion: –

The SFCL limits the fault current in the first cycle than any other devices. The simulation results shows the effectiveness of suggested scheme and also the ability of the SFCL to reduce the inrush current. By using SFCL for limiting the fault current the system reliability and integrity is increased.

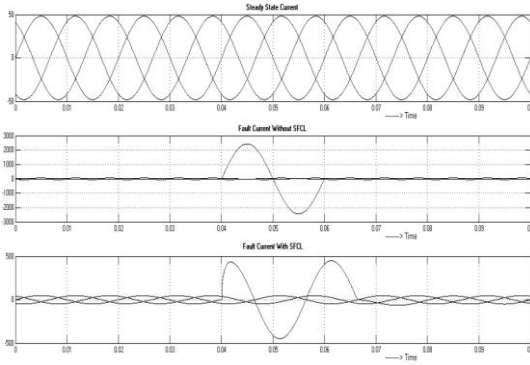

Fig: 6 During LG Fault

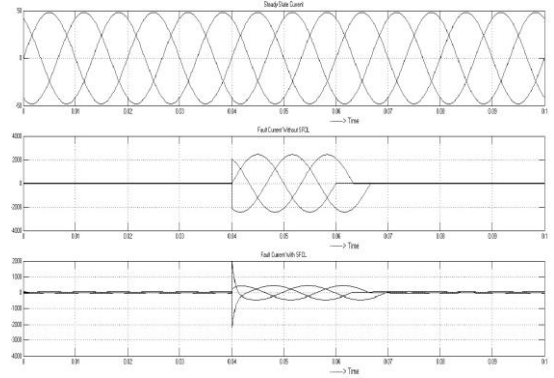

Fig: 10 During LLLG Fault

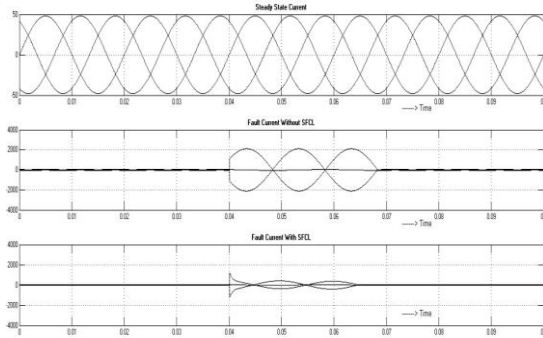

Fig: 7 During LL Fault

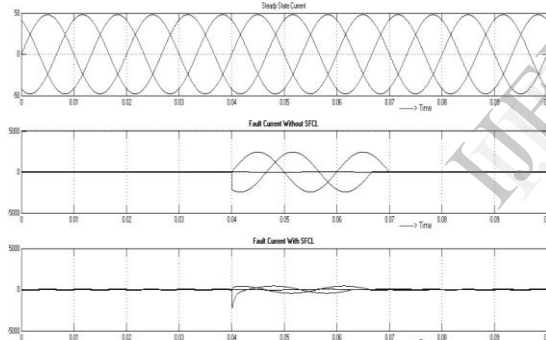

Fig: 8 During LLLG Fault

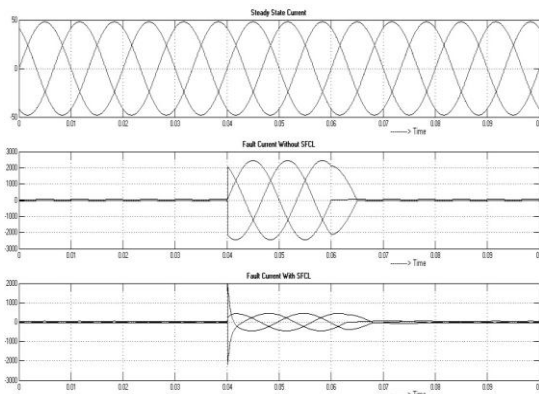

Fig: 9 During LLL Fault

Table 2: Fault current values with and without SFCL for different faults

Type of Fault	Magnitude of Fault Current (A)	
	Without SFCL	With SFCL
LG fault	2440	451
LL fault	2120	380
LLG fault	2445	450
LLL fault	2440	451
LLL fault	2445	450

4. Conclusions: –

We performed the fault analysis of resistive type superconducting fault current limiters with unbalanced faults of a single line-to-ground fault, a line-to-line fault, double line-to-ground fault, symmetrical faults in a three phase system.

Conclusion is summarized as follows:

1. The proposed model reduces the large fault currents to a lower managerial level (Six times approximately).
2. During Steady State the SFCL is inexistent. i.e., the voltage drop in the steady state is zero.
3. Detects the fault current within the first cycle of the fault.
4. As the Fault Current is reduced, the lower rating circuit breakers can be used in the system.

4. References: –

- [1] U.M.Mohana, Mrs.S.T.Suganthi “performance analysis of superconducting fault current limiter (sfcl) in single phase and three phase systems”
- [2] S. Nemdili · S. Belkhiat “Modeling and Simulation of Resistive Superconducting Fault-Current Limiters”
- [3] Steven M. Blair, Student Member, IEEE, Campbell D. Booth, and Graeme M. Burt, Member, IEEE “Current-Time Characteristics of Resistive Superconducting Fault Current Limiters”
- [4] G.G. Karady “Principles of fault current limitation by a resonant LC circuit”
- [5] Vladimir Sokolovsky, Victor Meerovich, István Vajda, Member, IEEE, and Vladimir Beilin, IEEE TRANSACTIONS ON APPLIED SUPER CONDUCTIVITY, VOL. 14, NO. 3, SEPTEMBER 2004 “Superconducting FCL: Design and Application”
- [6] G. Tang, Member, IEEE, and M. R. Iravani, Fellow, IEEE, “Application of a Fault Current Limiter To Minimize Distributed Generation Impact on Coordinated Relay Protection”
- [7] Lin Ye, Liang Zhen Lin, and Klaus-Peter Juengst IEEE TRANSACTIONS ON APPLIED SUPER CONDUCTIVITY, VOL. 12, NO. 1, MARCH 2002 “Application Studies of Superconducting Fault Current Limiters in Electric Power Systems”
- [8] Y. Shirai, Member, IEEE, K. Furushiba, Y. Shouno, M. Shiotsu, and T. Nitta, Member, IEEE IEEE TRANSACTIONS ON APPLIED SUPER CONDUCTIVITY, VOL. 18, NO. 2, JUNE 2008” Improvement of Power System Stability by Use of Superconducting Fault Current Limiter With ZnO Device and Resistor in Parallel”
- [9] Lin Ye and Klaus-Peter Juengst IEEE TRANSACTIONS ON APPLIED SUPER CONDUCTIVITY, VOL. 14, NO. 2, JUNE 2004 “Modeling and Simulation of High Temperature Resistive Superconducting Fault Current Limiters”
- [10] Victor Meerovich, Vladimir Sokolovsky, Joachim Bock, Stephan Gauss, Shaul Goren, and Grzegorz Jung IEE TRANSACTIONS ON APPLIED SUPER CONDUCTIVITY, VOL. 9, NO. 4, DECEMBER 1999 “Performance of an Inductive Fault Current Limiter Employing BSCCO Superconducting Cylinders”
- [11] Lin Ye and Liang Zhen Lin IEEE TRANSACTIONS ON APPLIED SUPERCONDUCTIVITY, VOL. 20, NO. 3, JUNE 2010 “Study of Superconducting Fault Current Limiters for System Integration of Wind Farms”
- [12] Hans-Peter Kraemer, Wolfgang Schmidt, Hong Cai, Bruce Gamble, David Madura, Tim MacDonald, Joe McNamara, Walther Romanosky, Greg Snitchler, Nicolas Lallouet, Frank Schmidt, Syed Ahmed “Superconducting Fault Current Limiter for Transmission Voltage”