



1st International Conference on Power Engineering, Computing and CONTROL, PECCON-2017, 2-4 March 2017, VIT University, Chennai Campus

Voltage Stability Improvement In Multi-bus System Using Static Synchronous Series Compensator

D. A. Ingole, Prof. Dr. V .N. Gohokar

M.E student, Department of EE, AISSMS, Pune, India

Professor, Department of EE, AISSMS, Pune, India

Abstract

Today's power system has become more complex due to open access electricity market activities and a increasing demand, for such network stability is an important issue. Among various types of stability, voltage instability and collapse become a concern problem all over the world. To maintain power system stability issues FACTS devices are used. In this paper a suitable approach to enhance the voltage stability of power system using static synchronous series compensator (SSSC) is studied. IEEE 4 bus system and IEEE 9 bus system is simulated using MATLAB Simulink software to study voltage stability and reactive power compensation. The performance of SSSC on voltage profile is analysed for multibus system. Simulation results demonstrate that voltage stability can be improved using of static synchronous series compensator.

© 2017 The Authors. Published by Elsevier Ltd.

Peer-review under responsibility of the scientific committee of the 1st International Conference on Power Engineering, Computing and CONTROL.

Keywords: Power system stability, FACTS, Reactive power compensation, Voltage stability, SSSC ;

1. Introduction

Now a day's power system is more interconnected so stability is the main issue. Continuously changing load demand and fault condition adversely affect the power system stability. Under heavy load conditions or change in system conditions voltages can drop considerably and even collapse. Voltage instability or voltage collapse is due to shortage of reactive power from generators and transmission line [1,2]. Voltage profile can be improved by controlling reactive power using FACTS devices because of several advantages over other controlling devices. Static synchronous series compensator (FACTS device) is shown its performance in terms of stability improvement. The role of SSSC is to control power transfer capability; it can also upgrade stability of power system. SSSC can improve the power transfer capability by adding inductive or capacitive inductance in transmission line [3,4,5].

In recent years various works is done to improve power system stability by using FACTS devices. The static synchronous series compensator (SSSC) is one of the FACTS device used to examine the effect of voltage stability. It consists of voltage source converter and coupling transformer connected in series with the transmission line. For the purpose of increasing or decreasing the overall reactive voltage drops across the line. Its output voltage is in quadrature with the line current. The SSSC can control the current and the power flowing through the line by controlling the reactive power exchange between the SSSC and the AC system. It can improve the voltages profile in the transient state. SSSC investigate the effect on current, voltage, active and reactive power in real time [6-7]. The problem of controlling and modulating power flow in a transmission line using a SSSC is analysed. Which include detailed techniques of twelve pulse and PWM controlled SSSC, are conducted and the control circuits are presented.

The application of SSSC based power oscillation damping controller to enhance the stability of IEEE 4 bus system is investigated in MATLAB software [8-9]. The problem of controlling and modulating power flow in transmission line under faulty condition is improved by using SSSC [10].

In this paper static synchronous series compensator is studied to improve the voltage stability by continuous voltage injection. The application of SSSC to improve voltage stability is applied to nine bus system. Initially the basic model of four bus system with and without SSSC is analysed. After that IEEE 9 bus system is simulated by using MATLAB software. All the output results of four bus and nine bus system illustrated that voltage profile is increased with the help of static synchronous series compensator.

This paper is structured as follows. The basics of voltage stability are described in section II. In section III, static synchronous series compensator theory concepts and fundamental equations are summarized. In section IV, test system description of IEEE 4 bus and IEEE 9 bus system with and without SSSC is described. Next the simulation and results of multi-bus systems with and without SSSC is demonstrated in section V. Finally section V gives the concluded remark. The IEEE 4 bus and IEEE 9 bus system is studied and voltage stability results are investigated using MATLAB Simulink software.

2. Voltage stability:

Voltage stability is the capability of a power system to sustained steady acceptable voltages at all buses in the system in normal operating conditions and after being subjected to disturbance. A system comes into a state of voltage instability when a disturbance, increase in load demand or change in system condition causes a progressive and uncontrollable drop in voltage.

The main factor causing instability is the inability of the power system to meet the demand of reactive power. The bus voltage magnitude increases as the reactive power injection at the same bus is increased. System is voltage unstable if, for at least one bus in the system, the bus voltage magnitude decreases as the reactive power injection at the same bus is increased.

Voltage instability may arise due many reasons, but some significant contributors are:

- Increase in loading
- Generators, synchronous condensers, or SVC reaching reactive power limits
- Action of tap changing transformers
- Load recovery dynamics
- Line tripping or generator outages

Most of these changes have a significant impact on the reactive power production, consumption and transmission in the system. Some counter measures to prevent voltage collapse are:

- Switching of shunt capacitors
- Blocking of tap-changing transformers
- Redispatch of generation
- Load shedding
- Temporary reactive power overloading of generators

3. Static synchronous series compensator:

Static synchronous series compensator SSSC is made up of a capacitor, a converter and a coupling transformer. Converter comprises several gate turn off thyristor switch-based valves to regulate the magnitude and the angle of the injected voltage.

Single line diagram of transmission line with an inductive reactance connecting to sending end voltage source and a receiving end voltage source is shown in figure 1. The real and reactive powers (P and Q) flows at the receiving end voltage source are given by

4.

$$P = \frac{V_s V_r}{X_L} \sin(\delta_s - \delta_r) = \frac{V^2}{X_L} \sin \delta \quad (1)$$

$$Q = \frac{V_s V_r}{X_L} (1 - \cos(\delta_s - \delta_r)) = V^2 / X_L \sin \delta \tag{2}$$

Where V_s and V_r are the magnitudes, δ_s and δ_r are the phase angle of the voltage sources V_s and V_r respectively. For simplicity the voltage magnitudes are chosen such those $V_s = V_r = V$ and the difference between the phase angle is $\delta_s = \delta_r = \delta$.

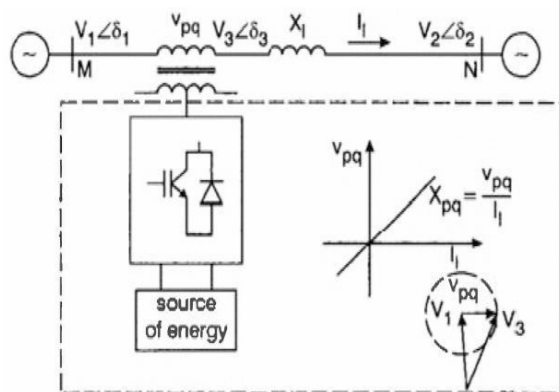

Fig. 1 single line diagram of simple transmission line

An SSSC restricted by its voltage and current rating. SSSC is capable of emulating a compensating reactance X_q (both inductive and capacitive) in series with the transmission line. The expression for real power and reactive power flow is given by

$$P_q = \frac{V^2}{x_{eff}} \sin \delta = \frac{V^2}{x_l(1 - X_q/X_l)} \sin \delta \tag{3}$$

$$Q = V^2 / X_{eff} (1 - \cos(\delta)) = \left\{ V^2 / X_l \left(1 - X_q / X_l \right) \right\} \sin \delta \tag{4}$$

The reactance of transmission lines after adding compensating reactance is replaced by X_{eff} . The compensating reactance X_q is negative when the SSSC is operated in an inductive mode and positive when SSSC is operated in a capacitive mode [11].

The expression for the injected voltage Vq can be written as:

$$Vq = \pm j Vq (\epsilon) I / I$$

Where Vq is the injecting compensating voltage ($0 \leq Vq (\epsilon) \leq V_{qmax}$). When SSSC injects an alternating voltage lagging the line current, it emulates a capacitive reactance in series with transmission line causing power flow to increase. When an SSSC injects an alternating voltage leading the line current, it emulates inductive reactance in series with transmission line causing power flow to decrease. According to the line voltage and the line current, the series controller control action is depends. By absorbing or producing reactive power provides the voltage stability in the power system.

4. Test System Description:

The simulation studies in this paper are based on 500 KV 2 machine four bus systems, 2 machine six bus system, 230 KV 3 machine 9 bus transmission system. The SSSC is installed at transmission line respectively to regulate power flow through that line as well as to control voltage level at buses.

4.1. Four bus system:

The IEEE two machines 4 bus system without and with SSSC is shown in figure 2.

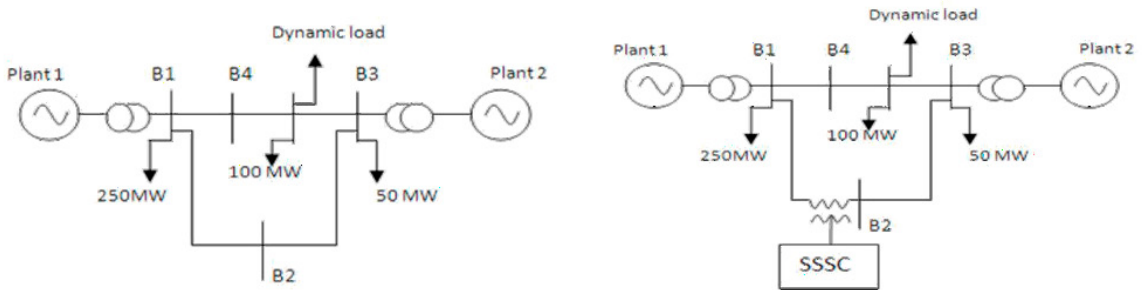

Fig 2: 4 bus systems without SSSC and with SSSC

The 500 KV transmission systems have been utilized to regulate the power flow. This system be made up of 4 buses (B1 to B4) which has been made in ring mode joined to each other through three phase transmission lines L1, L2-1, L2-2 and L3 with the length of 280, 150, 150 and 50 km respectively. There are two power plants with the phase-to-phase voltage equal to 13.8 Kv. Base parameters for plants 1 and 2 are $S_b=100\text{MVA}$ and $V_b=500\text{KV}$, which active and reactive powers of power plants 1 and 2 are $(24-j3.8)$ and $(15.6-j0.5)$ in per unit, respectively.

4.2. Nine bus system:

The single line diagram of 9 bus system is shown in figure 3. The system is connected in a loop configuration mode consisting of 9 buses (B1 to B9) connected to each other by transmission lines having length 1 through three phase transmission line and three 18 kV/230 kV transformer banks with power rated equal to 100 MVA. The system has been supplied by two power plants with phase to phase voltage 13.8 KV. The test system model comprises of IEEE 9 bus, 3 machine system, 300 Km, 500 kV shown in figure 3. Three generators are connected at Bus 1, Bus 2 and Bus 3 respectively.

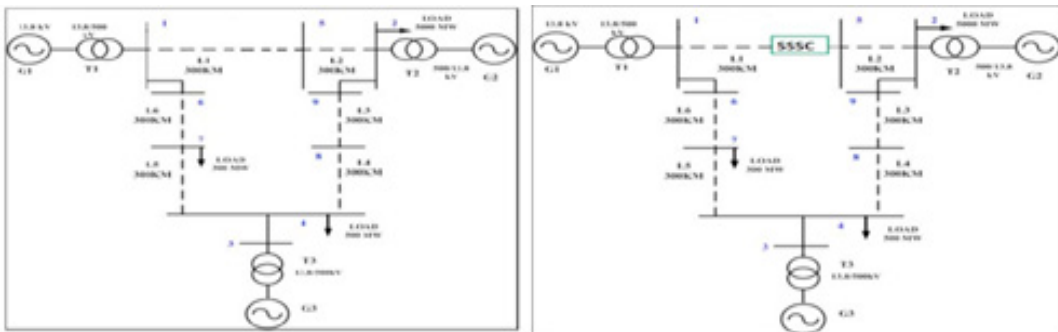

Fig 3 Single line diagram of IEEE nine bus systems without and with SSSC.

5. Simulation and results:

The multi-bus systems without and with SSSC are simulated in MATLAB software. Changes in current, voltage, active and reactive power have been obtained in real time.

5.1. 4 bus system:

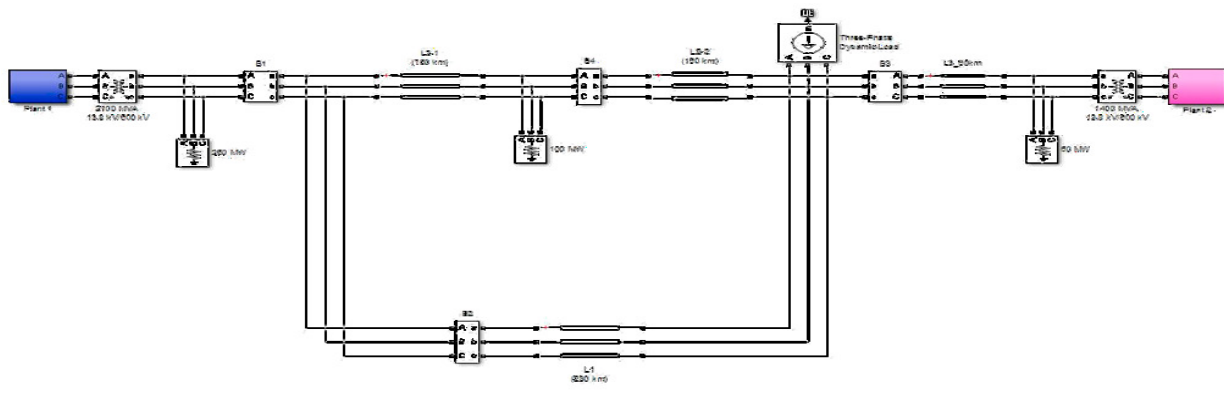

Fig 4: 4 bus system simulation diagram without SSSC

Simulation diagram for IEEE 4 bus system without SSSC is shown in figure 4. Dynamic load is connected to bus 2. Static synchronous series compensator is connected to two machine 4 bus system as shown in figure 5. After incorporating the system in MATLAB software, current, voltage, active and reactive power in bus 2 has been obtained. Table 1 and 2 shows the results of 4 bus systems without and with SSSC of bus 2.

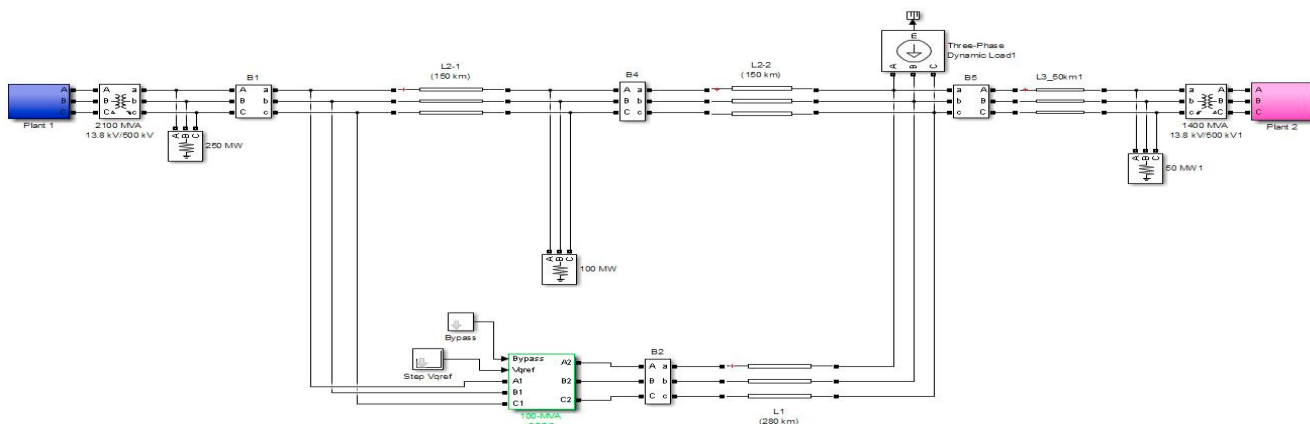

Fig. 5. 4 bus system simulation diagram with SSSC

Table 1: 4 bus system results without SSSC

BUS NO	VOLTAGE (pu)	CURRENT (pu)	P (pu)	Q (pu)
1	1.007	13.5	20.06	-3.76
2	1.007	6.7	9.95	-1.81
3	1.002	9.8	14.84	-0.48
4	1.015	5.5	8.45	-0.59

Table 2: 4 bus system results without with SSSC

BUS NO	VOLTAGE (pu)	CURRENT (pu)	P (pu)	Q (pu)
1	1	13.5	19.99	-4.74
2	0.9945	7.6	11.26	-1.84
3	1	9.8	14.82	-0.24
4	1	4.6	7.09	-0.24

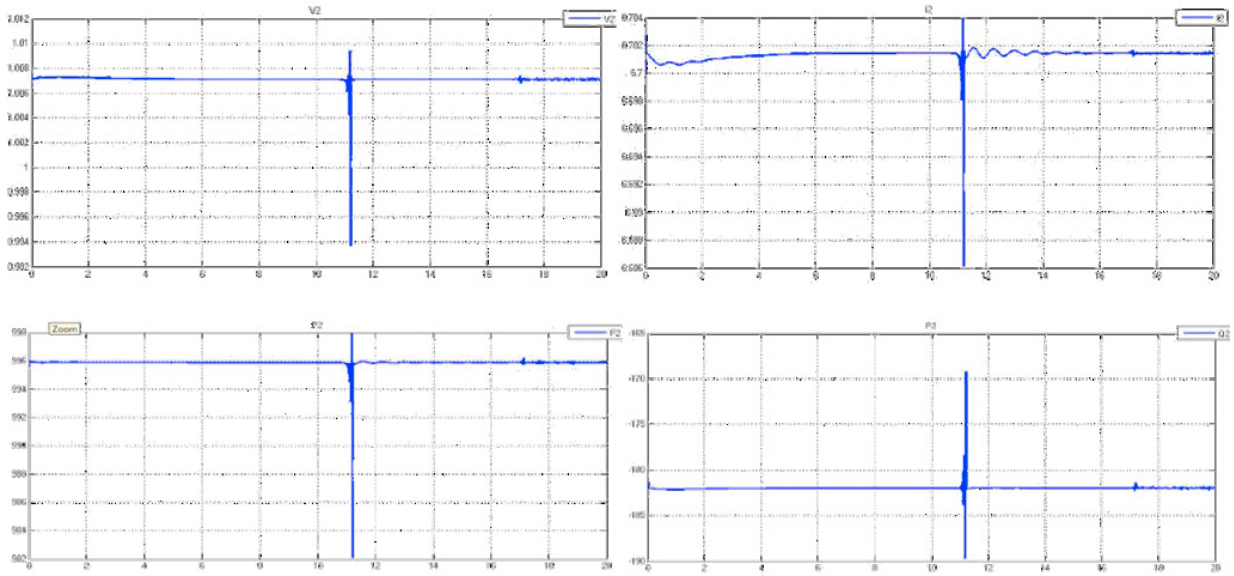

Fig. 6. 4 bus system results without SSSC

According to the results shown in 6 at first, due to the large loads of the system, bus 2 got oscillations. After installation of SSSC, time will be less than the mode without SSSC, active power damping time will be less than mode without SSSC and it will damped faster as shown in figure 7.

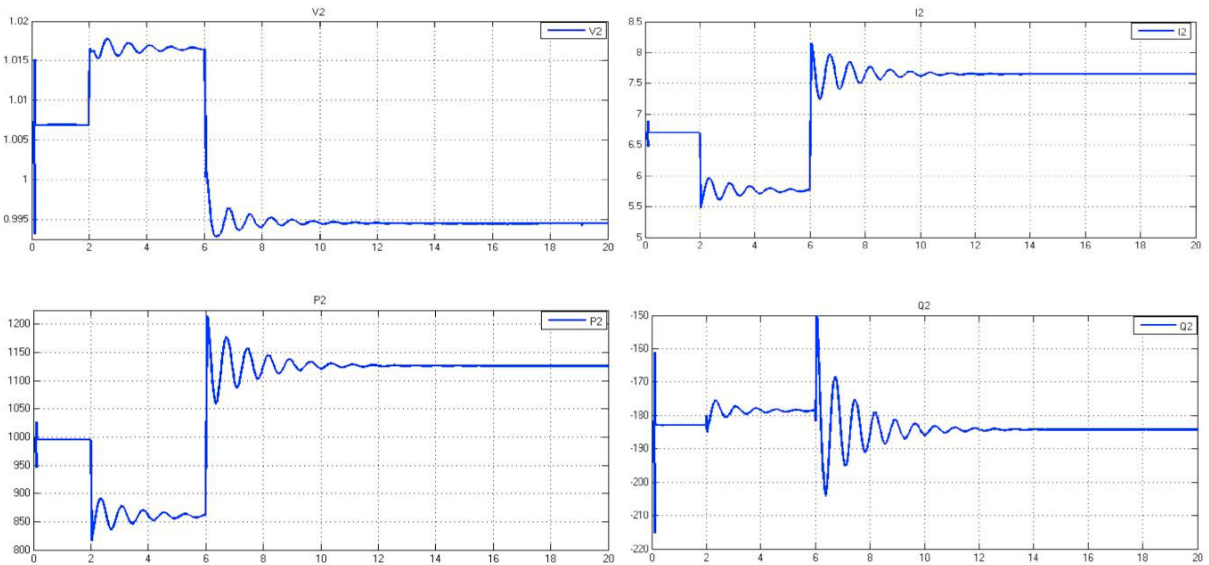

Fig. 7. 4 bus system results with SSSC

5.2. Nine Bus System:

Simulation diagram for IEEE 9 bus system without and with SSSC is shown in figure 8 and figure 9. Static synchronous series compensator is connected between bus 1 and bus 5 to three machine 9 bus system. After incorporating the system in MATLAB software, current, voltage, active and reactive power in all buses has been obtained. Table 3 and 4 shows the results of 9 bus systems without and with SSSC.

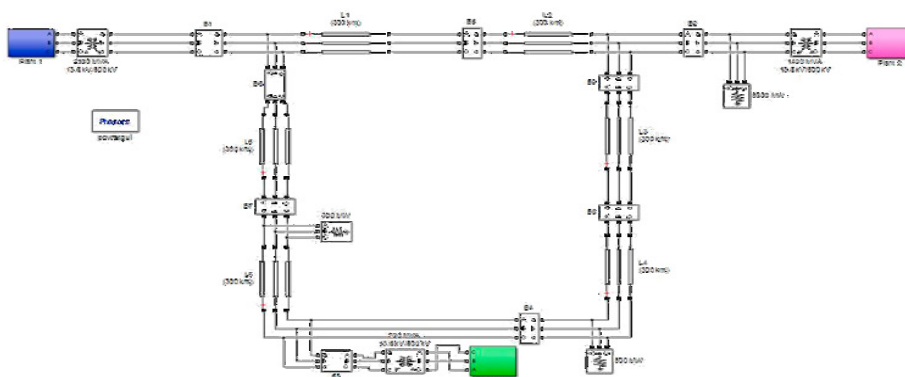

Fig. 8. Nine bus system simulation diagram with SSSC

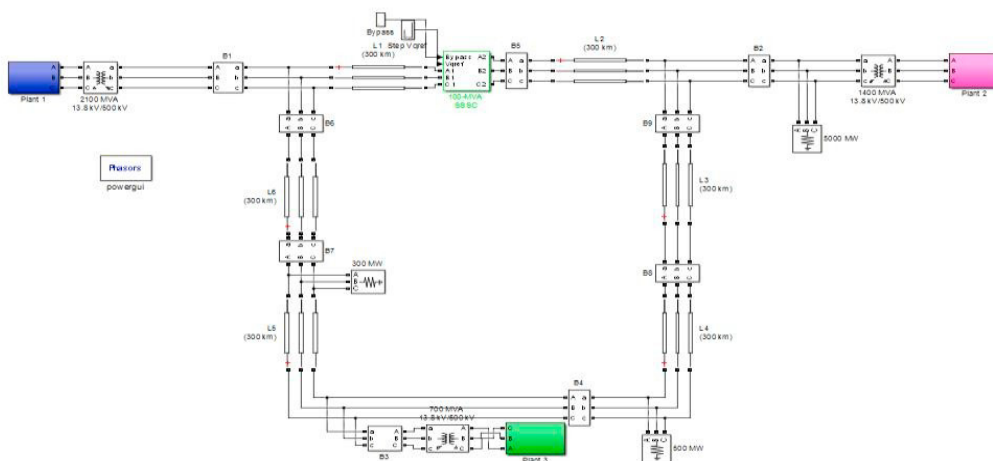

Fig. 9. Nine bus system simulation diagram with SSSC

Table 3: 9 bus system results without SSSC

Bus no	Voltage (pu)	Current(pu)	P(pu)	Q(pu)
1	0.9982	11.76	12.54	-13.63
2	1.002	8.093	0.6632	13.11
3	0.9992	6.596	4.026	-10.38
4	0.9992	5.37	6.874	-5.912
5	1.007	2.052	3.413	-0.9214
6	0.9982	7.178	9.072	-6.747
7	0.9974	5.318	8.895	-2.461
8	1.002	1.623	-2.659	1.159
9	1.002	4.982	-2.713	7.614

Power system with three machines nine buses after incorporating SSSC has been simulated in MATLAB environment, and then powers and voltages in all buses have been obtained. The results have been given in Table 5. Obtained results had proven that the voltage stability of power system parameters has been increased.

Table 4: 9 bus system results with SSSC

Bus no	Voltage (pu)	Current(pu)	P(pu)	Q(pu)
1	1	12.04	12.55	-14.27
2	1	7.851	0.6174	12.7
3	1	6.599	4.03	-10.4
4	1	5.099	6.408	-5.761
5	0.9975	2.373	3.86	-1.229
6	1	6.986	8.621	-6.876
7	1	5.046	8.457	-2.368
8	1	1.898	-3.144	1.262
9	1	5.105	-3.203	7.621

Conclusion

In this paper, the simulation of two machine four bus and three-machine nine Bus power system model with Static synchronous series compensator is performed. It can be clearly indicated that the static synchronous series compensator is capable of controlling the voltage at a desired point on the transmission line by injecting a fast changing voltage in series with the line and it keeps the constant of power flow. Use of the SSSC will be extended in future to a complex system to examine the problem correlated to the various power systems.

References:

1. P. Kundur, Power system stability and control. McGraw-hill, Inc
2. K R Padiyar Power system dynamics stability and control, BS publication
3. N. G. Hingorani and L. Gyugyi, Understanding FACTS, Concepts and Technology of Flexible AC Transmission Systems. Piscataway, NJ: IEEE Press, 2000.
4. K. K. Sen "SSSC – Static Synchronous Series Compensator: Theory, Modeling, And Applications", IEEE Transactions on Power Delivery, Vol. 13, No. 1, pp. 241 – 246, January 1998.
5. Sandeep Gupta, Prof. R. K. Tripathi, *Member, IEEE*, and RishabhDevShukla Voltage Stability Improvement in Power Systems using Facts Controllers: State-of-the-Art Review 2010.
6. S Arunkumar, C Easwarlal, M Senthilkumar " Multi machine power system stability enhancement using static synchronous series compensator(SSSC)" IEEE transaction international conference on computing, electronics and electrical technologies [ICCEET] 2012
7. M. Faridi, H. Maeiiat, M. Karimi, P. Farhadi and H. Mosleh (2011) "Power System Stability Enhancement Using Static Synchronous Series Compensator (SSSC)" IEEE Transactions on Power System, pp. 387-391.
8. H. Taheri, S. Shahabi, Sh. Taheri and A. Gholami (2009) "Application of Synchronous Static Series Compensator (SSSC) on Enhancement of Voltage Stability and Power Oscillation Damping", IEEE Transactions on Power System, pp. 533-539.
9. Maninderohal, prof. Ravi, Application of SSSC based power oscillation damping controller for transient stability enhancement of multimachine system for unsymmetrical faults.
10. B.M Naveen Kumar Reddy, G.V. Rajshekhar, Dr. HImanigoyal, power system stability enhancement using static synchronous series compensator (SSSC)
11. Laszlo Gyugyi, Colin D. Schauder, K.K. Sen (1997) "Static synchronous series compensator: A solid state art approach to the series compensation of transmission lines" IEEE Transactions on Power System, pp. 406-417