

# VSC-Based HVDC Power Transmission Systems: An Overview

Nikolas Flourentzou, *Student Member, IEEE*, Vassilios G. Agelidis, *Senior Member, IEEE*,  
and Georgios D. Demetriades, *Member, IEEE*

**Abstract**—The ever increasing progress of high-voltage high-power fully controlled semiconductor technology continues to have a significant impact on the development of advanced power electronic apparatus used to support optimized operations and efficient management of electrical grids, which, in many cases, are fully or partially deregulated networks. Developments advance both the HVdc power transmission and the flexible ac transmission system technologies. In this paper, an overview of the recent advances in the area of voltage-source converter (VSC) HVdc technology is provided. Selected key multilevel converter topologies are presented. Control and modeling methods are discussed. A list of VSC-based HVdc installations worldwide is included. It is confirmed that the continuous development of power electronics presents cost-effective opportunities for the utilities to exploit, and HVdc remains a key technology. In particular, VSC-HVdc can address not only conventional network issues such as bulk power transmission, asynchronous network interconnections, back-to-back ac system linking, and voltage/stability support to mention a few, but also niche markets such as the integration of large-scale renewable energy sources with the grid and most recently large onshore/offshore wind farms.

**Index Terms**—HVdc circuit breakers (CBs), HVdc converters, HVdc transmission, power electronics, power engineering education, power systems.

## I. INTRODUCTION

**H**VDC POWER transmission systems and technologies associated with the flexible ac transmission system (FACTS) continue to advance as they make their way to commercial applications [1]–[30]. Both HVdc and FACTS systems underwent research and development for many years, and they were based initially on thyristor technology and more recently on fully controlled semiconductors and voltage-source converter (VSC) topologies [1]–[30]. The ever increasing penetration of the power electronics technologies into the power systems is mainly due to the continuous progress of the high-voltage high-power fully controlled semiconductors [31]–[36].

The fully controlled semiconductor devices available today for high-voltage high-power converters can be based on either thyristor or transistor technology (see Table I). These devices can be used for a VSC with pulsewidth modulation (PWM)

Manuscript received February 13, 2008; revised June 5, 2008 and August 14, 2008. First published February 3, 2009; current version published April 8, 2009. Recommended for publication by Associate Editor J. H. R. Enslin.

N. Flourentzou and V. G. Agelidis are with the School of Electrical and Information Engineering, The University of Sydney, Sydney, N.S.W. 2006, Australia (e-mail: nflourentzou@ee.usyd.edu.au; v.agelidis@ee.usyd.edu.au).

G. D. Demetriades is with ABB Corporate Research, SE-721 78 Västerås, Sweden (e-mail: georgios.demetriades@se.abb.com).

Digital Object Identifier 10.1109/TPEL.2008.2008441

TABLE I  
SUMMARY OF FULLY CONTROLLED HIGH-POWER SEMICONDUCTORS

Acronym	Type	Full Name
IGBT	Transistor	Insulated Gate Bipolar Transistor
IEGT	Transistor	Injection Enhanced Gate Transistor
GTO	Thyristor	Gate Turn-off Thyristor
IGCT	Thyristor	Integrated Gate Commutated Thyristor
GCT	Thyristor	Gate Commutated Turn-off Thyristor

operating at frequencies higher than the line frequency. These devices are all self-commuted via a gate pulse.

Typically, it is desirable that a VSC application generates PWM waveforms of higher frequency when compared to the thyristor-based systems. However, the operating frequency of these devices is also determined by the switching losses and the design of the heat sink, both of which are related to the power through the component. Switching losses, which are directly linked to high-frequency PWM operation, are one of the most serious and challenging issues that need to be dealt with in VSC-based high-power applications. Other significant disadvantages that occur by operating a VSC at high frequency are the electromagnetic compatibility/electromagnetic interference (EMC/EMI), transformer insulation stresses, and high-frequency oscillations, which require additional filters.

HVdc and FACTS systems are important technologies, supporting in their own way the modern power systems, which, in many cases, are fully or partially deregulated in several countries [37]. In the near future, even higher integration of electrical grids and market-driven developments are expected, as for instance, countries in the Middle East, China, India, and South America require infrastructure to power their growth and interconnection of “island” grids [38]–[43].

Today, there are approximately 100 HVdc installations worldwide (in operation or planned for the very near future) transmitting more than 80 GW of power employing two distinct technologies as follows.

- 1) Line-commutated current-source converters (CSCs) that use thyristors (Fig. 1, CSC-HVdc): This technology is well established for high power, typically around 1000 MW, with the largest project being the Itaipu system in Brazil at 6300 MW power level. The longest power transmission in the world will transmit 6400 MW power from the Xiangjiaba hydropower plant to Shanghai. The 2071 km line will use 800 kV HVdc and 1000 kV ultrahigh-voltage ac transmission technology [44].
- 2) Forced-commutated VSCs that use gate turn-off thyristors (GTOs) or in most industrial cases insulated gate

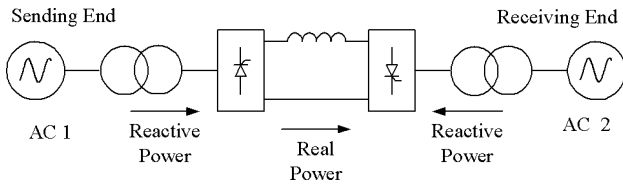

Fig. 1. HVDC system based on CSC technology with thyristors.

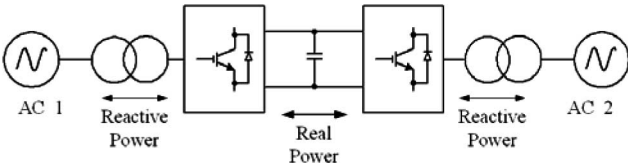

Fig. 2. HVDC system based on VSC technology built with IGBTs.

bipolar transistors (IGBTs) (Fig. 2, VSC-HVdc): It is well-established technology for medium power levels, thus far, with recent projects ranging around 300–400 MW power level (see Table II) [45]–[55].

The CSC-HVdc systems represent mature technology today (i.e., also referred to as “classic” HVdc), and recently, there have been a number of significant advances [56]–[58]. It is beyond the scope of this paper to discuss developments associated with the CSC-HVdc that are well documented in [56]–[58].

On the other hand, VSC-HVdc systems represent recent developments in the area of dc power transmission technology [48]. The experience with VSC-HVdc at commercial level scatters over the last 12 years [45]–[47], [49]–[55]. The breakthrough was made when the world’s first VSC-based PWM-controlled HVdc system using IGBTs was installed in March 1997 (Hellsjön project, Sweden, 3 MW, 10 km distance,  $\pm 10$  kV) [46], [47]. Since then, more VSC-HVdc systems have been installed worldwide (see Table II) [49]–[55].

The CSCs have the natural ability to withstand short circuits as the dc inductors can assist the limiting of the currents during faulty operating conditions. The VSCs are more vulnerable to line faults, and therefore, cables are more attractive for VSC-HVdc applications. It is worth mentioning relevant developments that led to the success of VSC-HVdc such as the advanced extruded dc cable technologies [59]–[61]. Faults on the dc side of VSC-HVdc systems can also be addressed through the use of dc circuit breakers (CBs) [62]–[68]. In the event of the loss of a VSC in a multiterminal HVdc, the excess of power can be restricted by the advanced dc voltage controller [69].

The objective of this paper is to provide an overview of the HVdc technologies associated with VSC-based systems including converter topologies. Modeling and control are another area of importance, and recent contributions presented in the technical literature are analyzed briefly. Finally, emerging applications of VSC-HVdc systems and multiterminal dc configurations that can be used to interconnect large-scale wind energy sources with the grid are discussed.

The paper is organized as follows. Section II provides a summary of the CSC-HVdc system configurations, which also apply, with some modifications, to the VSC-HVdc ones as well.

Section III discusses in detail the fundamental concepts associated with the VSC-HVdc system. The various multilevel converter topologies suitable for VSC-HVdc are presented in Section IV. Modeling and control issues are mentioned in Section V. Technical issues associated with dc faults, dc CBs, and isolation/reconnection of the dc network of multiterminal systems are discussed in Section VI. Emerging applications involving the integration of large-scale wind energy systems are presented in Section VII. The various worldwide VSC-HVdc projects are summarized in Section VIII.

## II. CSC-HVDC SYSTEM CONFIGURATIONS

Depending upon the function and location of the converter stations, various configurations of HVdc systems can be identified. The ones presented in this section involve CSC-HVdc configurations but similar types of configurations exist for VSC-HVdc with or without transformers depending upon the project in question.

### A. Back-to-Back CSC-HVDC System

In this case, the two converter stations are located at the same site and there is no transmission of power with a dc link over a long distance. A block diagram of a back-to-back CSC-HVdc system with 12-pulse converters is shown in Fig. 3. The two ac systems interconnected may have the same or different frequency (asynchronous interconnection).

### B. Monopolar CSC-HVDC System

In this configuration, two converters are used that are separated by a single pole line, and a positive or a negative dc voltage is used. Many of the cable transmissions with submarine connections use a monopolar system. The ground is used to return current. Fig. 4 shows a block diagram of a monopolar CSC-HVdc system with 12-pulse converters.

### C. Bipolar CSC-HVDC System

This is the most commonly used configuration of a CSC-HVdc system in applications where overhead lines are used to transmit power. In fact, the bipolar system is two monopolar systems. The advantage of such system is that one pole can continue to transmit power in case the other one is out of service for whatever reason. In other words, each system can operate on its own as an independent system with the earth return. Since one is positive and one is negative, in case that both poles have equal currents, the ground current is zero theoretically, or, in practice, within a difference of 1%. The 12-pulse-based bipolar CSC-HVdc system is depicted in Fig. 5.

### D. Multiterminal CSC-HVDC System

In this configuration, there are more than two sets of converters. A multiterminal CSC-HVdc system with 12-pulse converters per pole is shown in Fig. 6. In this case, converters 1 and 3 can operate as rectifiers while converter 2 operates as an inverter. Working in the other order, converter 2 can operate as a rectifier and converters 1 and 3 as inverters. By mechanically switching

TABLE II  
SUMMARY OF WORLDWIDE VSC-HVDC PROJECTS AND THEIR BASIC PARAMETERS

Project Name	Year of Commission	Power rating	Number of circuits	AC voltage	DC voltage	Length of DC cables	Comments and reasons for choosing VSC-HVDC	Topology	Semi-conductors
Hellsjön, Sweden	1997	3 MW ±3 MVar	1	10 kV (both ends)	± 10 kV	10 km Overhead lines	Test transmission. Synchronous AC grid.	2-level	IGBTs (series connected)
Gotland HVDC Light, Sweden	1999	50 MW -55 to +50 MVar	1	80 kV (both ends)	± 80 kV	2 × 70 km Submarine cables	Wind power (voltage support). Easy to get permission for underground cables.	2-level	IGBTs (series connected)
Eagle Pass, USA	2000	36MW ±36 MVar	1	138 kV (both sides)	± 15.9 kV	Back-to-back HVDC Light station	Controlled asynchronous connection for trading. Voltage control. Power exchange.	3-level NPC	IGBTs (series connected)
Tjæreborg, Denmark	2000	8 MVA 7.2 MW -3 to +4 MVar	1	10.5 kV (both sides)	± 9 kV	2 × 4.3 km Submarine	Wind power. Demonstration project. Normally synchronous AC grid with variable frequency control.	2-level	IGBTs (series connected)
Terrenora Interconnection (Directlink), Australia	2000	180 MW -165 to +90 MVar	3	110 kV – Bungalora 132 kV – Mullumbimby	± 80 kV	6 × 59 km Underground cable	Energy trade. Asynchronous AC grid. Easy to get permission for underground cables.	2-level	IGBTs (series connected)
MurrayLink, Australia	2002	220 MW -150 to +140 MVar	1	132 kV – Berri 220 kV – Red Cliffs	± 150 kV	2 × 180 km Underground cable	Controlled asynchronous connection for trading. Easy to get permission for underground cables.	3-level ANPC	IGBTs (series connected)
CrossSound, USA	2002	330 MW ±150 MVar	1	345 kV – New-Heaven 138 kV – Shoreham	± 150 kV	2 × 40 km Submarine cables	Controlled synchronous connection for power exchange. Submarine cables.	3-level ANPC	IGBTs (series connected)
Troll A offshore, Norway	2005	84 MW -20 to +24 MVar	2	330 kV – Kollsnes 56 kV – Troll	± 60 kV	4 × 70 km Submarine cables	Environment, CO <sub>2</sub> tax. Long submarine cable distance. Compactness of converter on platform electrification.	2-level	IGBTs (series connected)
Estlink, Estonia-Finland	2006	350 MW ±125 MVar	1	330 kV – Estonia 400 kV – Finland	± 150 kV	2 × 31 km Underground 2 × 74 km Submarine	Length of land cable, sea crossing and non-synchronous AC systems.	2-level	IGBTs (series connected)
NORD E.ON 1, Germany	2009	400 MW	1	380 kV – Diele 170 kV – Borkum 2	± 150 kV	2 × 75 km Underground 2 × 128 km Submarine	Offshore wind farm to shore. Length of land and sea cables. Asynchronous system.	-----	IGBTs (series connected)
Caprivi Link, Namibia	2009	300 MW	1	330 kV – Zambezi 400 kV – Gerus	350 kV	970 km Overhead lines	Synchronous AC grids. Long distance, weak networks.	-----	IGBTs (series connected)
Valhall offshore, Norway	2009	78 MW	1	300 kV – Lista 11 kV – Valhall	150 kV	292 km Submarine coaxial cable	Reduce cost and improve operation efficiency of the field. Minimize emission of green house gases.	2-level	IGBTs (series connected)

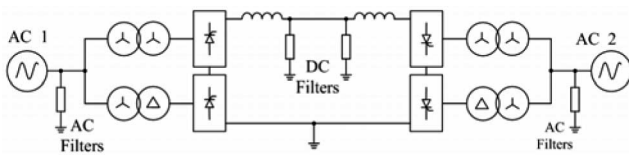

Fig. 3. Back-to-back CSC-HVDC system with 12-pulse converters.

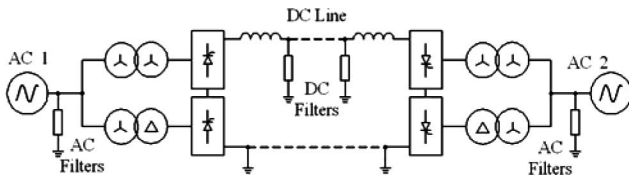

Fig. 4. Monopolar CSC-HVDC system with 12-pulse converters.

the connections of a given converter, other combinations can be achieved.

### III. VSC-HVDC FUNDAMENTAL CONCEPTS

A basic VSC-HVdc system comprises of two converter stations built with VSC topologies (see Fig. 2). The simplest VSC topology is the conventional two-level three-phase bridge shown in Fig. 7.

Typically, many series-connected IGBTs are used for each semiconductor shown (see Fig. 7) in order to deliver a higher blocking voltage capability for the converter, and therefore in-

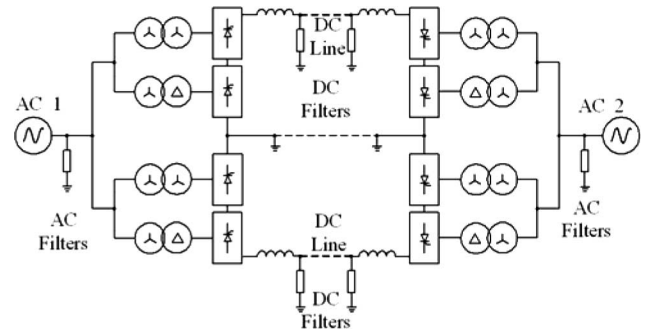

Fig. 5. Bipolar CSC-HVDC system with one 12-pulse converter per pole.

crease the dc bus voltage level of the HVdc system. It should be noted that an antiparallel diode is also needed in order to ensure the four-quadrant operation of the converter. The dc bus capacitor provides the required storage of the energy so that the power flow can be controlled and offers filtering for the dc harmonics. The VSC-HVdc system can also be built with other VSC topologies. Key topologies are presented in Section IV.

The converter is typically controlled through sinusoidal PWM (SPWM), and the harmonics are directly associated with the switching frequency of each converter leg. Fig. 8 presents the basic waveforms associated with SPWM and the line-to-neutral voltage waveform of the two-level converter (see Fig. 7). Each phase leg of the converter is connected through a reactor to the

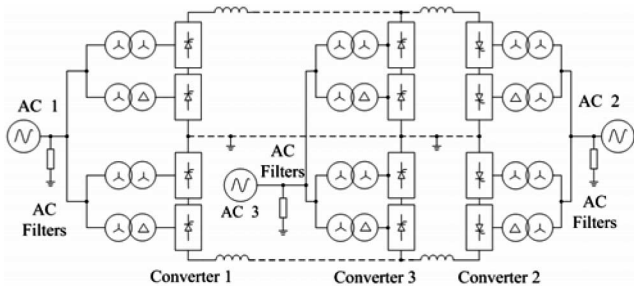

Fig. 6. Multiterminal CSC-HVDC system—parallel connected.

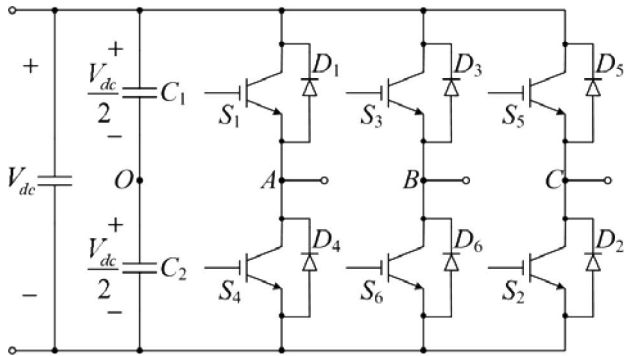

Fig. 7. Conventional three-phase two-level VSC topology.

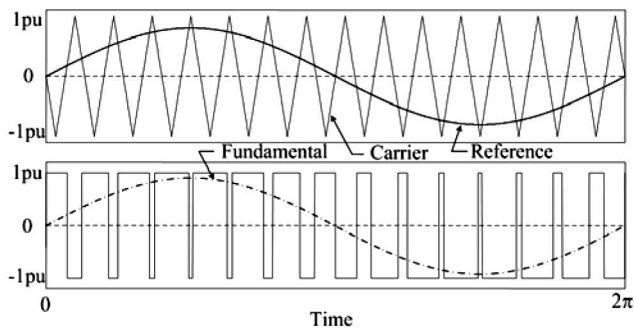

Fig. 8. Two-level sinusoidal PWM method: reference (sinusoidal) and carrier (triangular) signals and line-to-neutral voltage waveform.

ac system. Filters are also included on the ac side to further reduce the harmonic content flowing into the ac system.

Generalized two ac voltage sources connected via a reactor is shown in Fig. 9. Fig. 10 shows the relative location of the phasors of the two ac sinusoidal quantities and their relationship through the voltage drop across the line reactor (see Fig. 9). One voltage is generated by the VSC and the other one is the voltage of the ac system. At the fundamental frequency, the active and reactive powers are defined by the following relationships, assuming that the reactor between the converter and the ac system is ideal (i.e., lossless):

$$P = \frac{V_s \sin \delta}{X_L} V_r \quad (1)$$

$$Q = \frac{V_s \cos \delta - V_r}{X_L} V_r \quad (2)$$

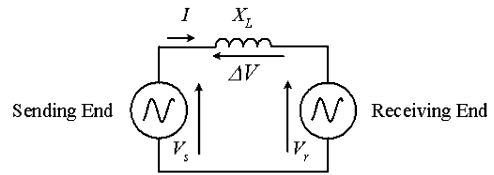

Fig. 9. Interconnection of two ac voltage sources through a lossless reactor.

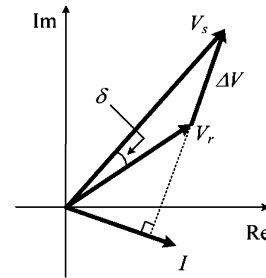

Fig. 10. Phasor diagram of two ac voltage sources interconnected through a lossless reactor.

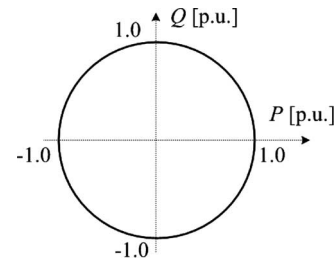

Fig. 11. Active–reactive locus diagram of VSC-based power transmission system.

where  $\delta$  is the phase angle between the voltage phasors  $V_s$  and  $V_r$  at the fundamental frequency.

Fig. 11 shows the entire active–reactive power area where the VSC can be operated with 1.0 per unit (p.u.) value being the megavolt amperes rating of each converter (assuming that the HVdc operates in ideal conditions). The use of VSC as opposed to a line-commutated CSC offers the following advantages.

- 1) Avoidance of commutation failures due to disturbances in the ac network.
- 2) Independent control of the reactive and active power consumed or generated by the converter.
- 3) Possibility to connect the VSC-HVdc system to a “weak” ac network or even to one where no generation source is available, and naturally, the short-circuit level is very low.
- 4) Faster dynamic response due to higher PWM than the fundamental switching frequency (phase-controlled) operation, which further results in reduced need for filtering, and hence smaller filter size.
- 5) No need of transformers to assist the commutation process of the converter’s fully controlled semiconductors.

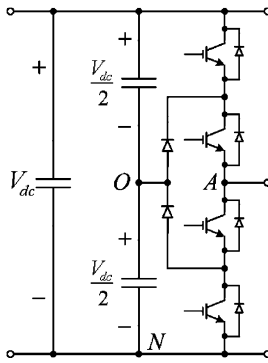

Fig. 12. NPC phase leg.

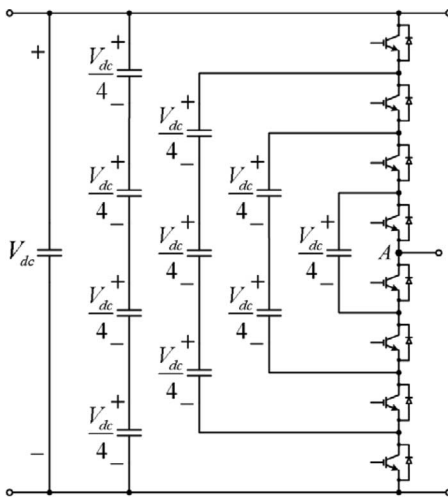

Fig. 13. Five-level FC VSC phase leg.

#### IV. VSC-HVDC MULTILEVEL TOPOLOGIES

In this section, different selected VSC topologies suitable for the implementation of a VSC-HVdc system are discussed. Multilevel converters extend the well-known advantages of low- and medium-power PWM converter technology into the high-power applications suitable for high-voltage high-power adjustable-speed drives and large converters for power systems through VSC-based FACTS and HVdc power transmission [70]–[86].

There are numerous multilevel solid-state converter topologies reported in the technical literature [74]. However, there are two distinct topologies, namely, the diode-clamped neutral-point-clamped (NPC) converter (see Fig. 12) [70] and the flying capacitor (FC) converter (see Fig. 13) [71], [72]. For clarity purposes, three-level and five-level PWM voltage waveforms on the line-to-neutral basis are shown in Figs. 14 and 15, respectively.

Contributions for selected topologies that can be used to build an HVdc system were made in numerous technical papers and are not limited to [78]–[102]. Specifically, PWM-controlled HVdc concepts based on the three-phase two-level converter were reported using GTOs in [87]. A similar system was developed and reported using IGBTs and DSP con-

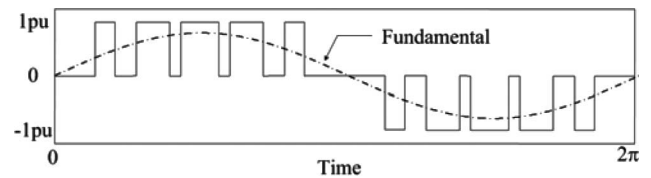

Fig. 14. Three-level PWM line-to-neutral voltage waveform.

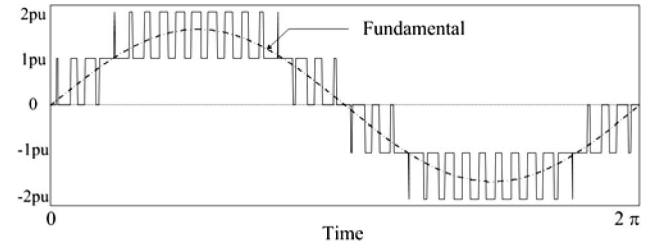

Fig. 15. Five-level PWM line-to-neutral voltage waveform.

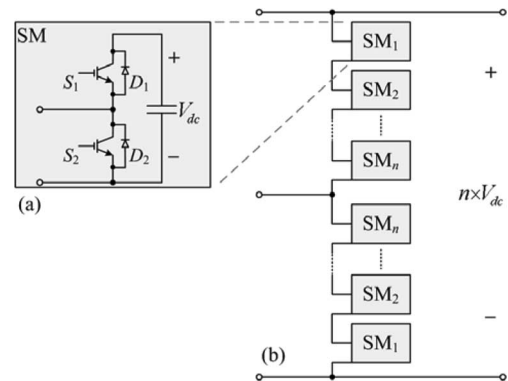

Fig. 16. Module-multilevel converter topology. (a) Structure of the submodule (SM). (b) Phase leg.

rol in [93]. Using modular approach and phase-shifted SPWM concepts, a number of advantages can be gained as far as the harmonic performance of the overall VSC-HVdc system is concerned [88], [89], [91], [101]. The modular multilevel converter using half-bridge cascaded connections [see Fig. 16(a)] that seems to be more suitable for different number of voltage levels [see Fig. 16(b)] is presented in [81] and examined for HVdc applications [82], [83]. The diode-clamped NPC topology was studied in [90] for an HVdc system in its three-level version (see Fig. 12). The benefits of using such a system were brought out; however, the converter has significant challenges with voltage balancing across the various dc bus capacitors, in addition to the uneven loss distribution between the devices. An actively clamped topology that is able to offer a solution to the loss distribution problem of the NPC was introduced in [78] and is called active NPC (ANPC) converter (see Fig. 17). This topology is an attractive solution for HVdc applications.

A VSC-HVdc system based on the five-level PWM FC topology was studied in [92] (see Fig. 13). The three basic topologies, namely the two-level converter (see Fig. 7), the NPC converter

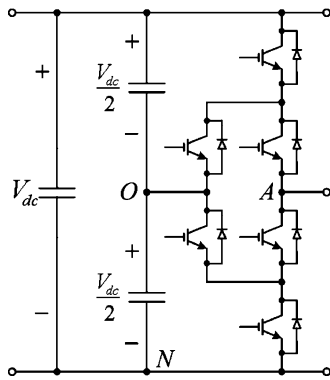

Fig. 17. ANPC phase leg.

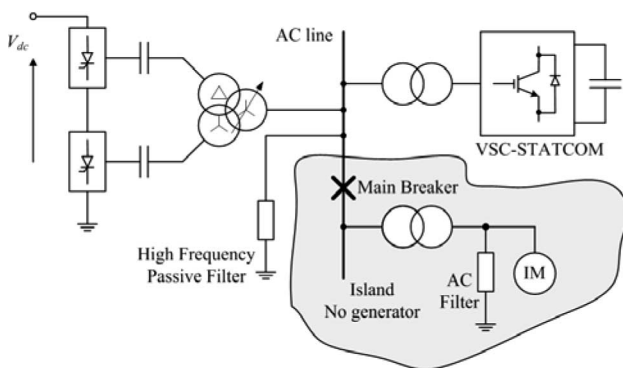

Fig. 18. Hybrid CSC-based HVDC combined with VSC-based STATCOM [94].

(see Fig. 12), and the FC converter (see Fig. 13), were compared for the HVdc system in [84]. A hybrid system is proposed in [94] as a way to exploit the benefits of more than one technology, i.e., the advantages of CSC-based HVdc and VSC-based static synchronous compensator (STATCOM) used as a static compensator for the connection of two ac systems when there is no synchronous generation to a main grid. The proposed system is shown in Fig. 18. The system studied through simulations combines the robust performance and relatively lower capital cost due to the low frequency switching with the fast dynamic response of a PWM-controlled VSC STATCOM. The power level of the STATCOM is not as high as the power level of the CSC-based HVdc. The multilevel FC topology and its operation under fault ac conditions were discussed in [96] and [97]. The control of the FC VSC-based HVdc system by selective harmonic elimination (SHE) PWM, hybrid SHE-PWM, and SPWM strategies was presented in [95] and [102]. Advances of SHE-PWM techniques that result in a reduced switching frequency were discussed in [103] and [104]. Space vector modulation (SVM) methods are also investigated to minimize the switching losses [91], [101]. Recently, VSC transmission topologies based on the multilevel current/voltage reinjection concept have been reported in [79], [80], and [98]–[100]. The configuration in [85] generates multilevel voltage waveforms with about 5% of total harmonic distortion under the fundamental switching frequency for the main bridges and six times the fundamental switching

frequency for the reinjection bridge without the assistance of filters or PWM. Another multilevel configuration that is suited for high-voltage ratings is proposed in [79] and [80].

## V. MODELING AND CONTROL

The large number of technical papers associated with VSC-HVdc systems, in the area of modeling and control, is not limited to [105]–[111]. A dc bus voltage control system using equivalent continuous-time state-space average modeling was presented in [105]. It is shown in [106] that including a back-to-back VSC-HVdc system at the midpoint of a transmission line can increase the transmissibility of the line by a factor of 1.68. It is shown in [107] that the VSC-HVdc system can be operated as a static synchronous series compensator (SSSC). Recently, a control system for the VSC-HVdc during island operation and under three-phase balanced faults was investigated in [108], and it has been found that the current limit of the converters has a significant influence on the dynamic response of the system. Finally, a dynamic model for a back-to-back HVdc system based on the three-level NPC topology was presented in [109].

## VI. HVDC CBs

The availability of dc CBs is limited. DC CBs are commonly used in traction applications [62]–[67] but the voltage and current ratings of these devices are considerably lower than what would be required in HVdc and multiterminal applications. The use of the dc CBs is feasible if a number of breakers are connected in series. Series connection of the dc breakers implies that all breakers should commutate simultaneously. Any time delays or breaker mismatching will result in breaker failure.

A plethora of publications exists in the literature concerning mechanical, solid-state, and hybrid ac CBs. On the other hand, only a few scientific publications are available studying the feasibility of different solutions concerning dc CBs. The different dc CBs topologies can be divided into three categories as follows.

- 1) A configuration employing a conventional ac CB and:
  - a) a charged capacitor in parallel with the breaker;
  - b) a resonance circuit is connected in parallel with the breaker.
- 2) A solid-state CB that can consist of:
  - a) a controllable device such as IGBT, integrated gate commutated thyristor (IGCT), GTO, with an antiparallel diode;
  - b) a bidirectional switch that consists of controllable devices and diodes.
- 3) A hybrid dc CB where a solid-state breaker, uni- or bidirectional configuration, is connected in parallel with a conventional ac CB.

During a dc fault, the antiparallel diodes of the three legs of the converter conduct as a rectifier to feed the fault. The fault can be cleared either by ac CBs without protecting the VSC or by breakers at the dc side. Two IGBT CBs (IGBT-CBs) are required for each converter of a two-terminal VSC-based HVdc system. For a multiterminal system, the IGBT-CBs can

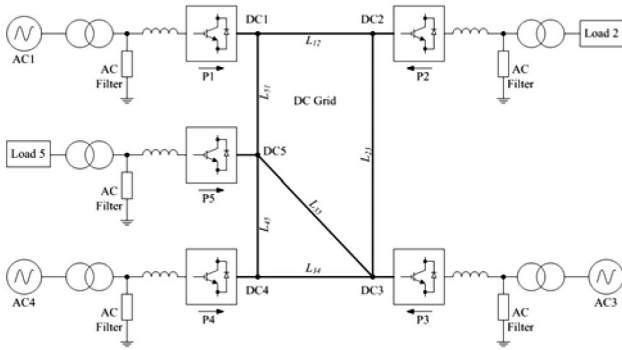

Fig. 19. Five-terminal VSC-HVDC system [112].

be placed between each VSC and the dc network or at each end of a dc branch line [68].

When IGBT-CBs are placed between each VSC and the dc network, mechanical switches are placed at each end of a dc branch line. During dc fault, the VSCs are isolated from the dc network by blocking of IGBT-CBs and give sufficient time for the arc to deionize. For a temporary fault, the system can be restored by unblocking of IGBT-CBs. If there is a permanent fault, the mechanical switches can be opened to isolate the fault, and then unblock the breakers to resume operation [68].

An alternative method that may imply higher cost is to place the IGBT-CBs at each end of a dc branch line. Therefore, the dc fault can be isolated from the VSCs directly, without the need of extinguishing of the fault current.

## VII. EMERGING APPLICATIONS

VSC-HVdc can be effectively used in a number of key areas as follows [45]–[55]:

- 1) small, isolated remote loads;
- 2) power supply to islands;
- 3) infeed to city centers;
- 4) remote small-scale generation;
- 5) offshore generation and deep-sea crossings;
- 6) multiterminal systems.

As a way of example, a five-terminal VSC-HVdc [112] and a multiterminal configuration [113] are shown in Figs. 19 and 20, respectively.

From the technology point of view, wind farms and offshore wind farms in particular are well suited for VSC-HVdc application [114], [115]. The discussion continues as to whether the dc is more cost-effective to the ac counterpart as a means to connect wind farms with the main grid [116]. Evaluation of grid connecting offshore wind farms through a dc link and their technical and economic analyses are recently presented in [117]. The opportunity to use dc systems based on permanent-magnet generators and medium-frequency transformers, as opposed to 50/60 Hz generators and transformers, has been presented offering more compact and light solution for offshore wind farms [128].

Multiterminal dc systems have been studied for wind farms and work is reported in [112], [118], and [119].

Fig. 21 presents a scenario of three wind generators connected through dc into a multiterminal grid through a VSC connection,

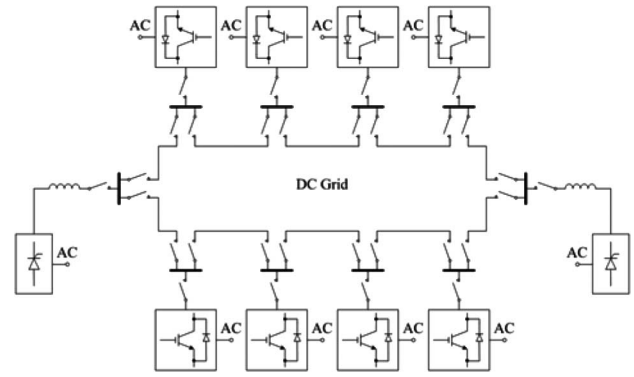

Fig. 20. Single-line multiterminal VSC-HVDC system [113].

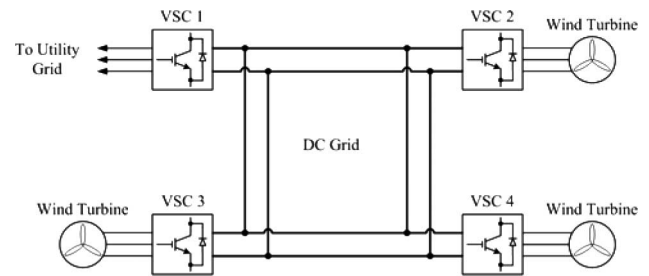

Fig. 21. Four-terminal PWM VSC-based HVDC system for wind turbines/wind parks [118].

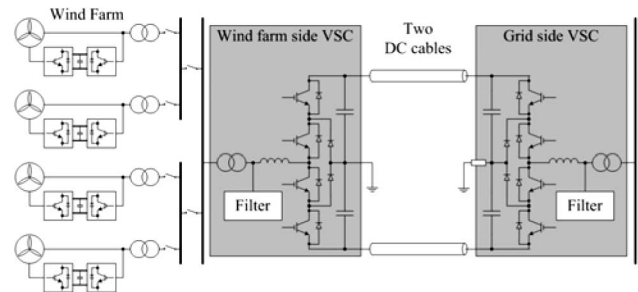

Fig. 22. Single-line diagram of wind farm integration using VSC transmission based on the three-level NPC converter [120].

and a single VSC-HVdc transmits the power and/or connects the entire farm with the grid.

The use of doubly fed induction generators (DFIGs) for wind farm development and the relation to an HVdc interconnection and coordinated control is one of the most current research developments in the field [120]–[127]. Fig. 22 shows the diagram of a DFIG-based wind farm integration using the VSC-HVdc transmission system [120].

The proliferation of power electronics technologies over past two decades has forced the field to reevaluate the potential of renewable energy and dc distribution grids. Recent developments include a low-voltage dc industrial power distribution system without a central control unit [129], a study of the impact of power quality and distributed generation based on the low-voltage dc distribution system [130], and analysis of

power systems for dc distribution [131]. Analysis of the efficiency of low- and medium-voltage dc distribution systems confirms the benefits of considering dc [132]. Theoretical studies of feasibility that included new storage technologies based on superconductivity [133] and commercial facilities based on dc were also conceptually considered [134].

### VIII. VSC-HVDC INSTALLATIONS

In this section, the various projects worldwide where VSC-based HVdc systems have been successfully exploited are discussed. The projects are summarized in Table II. They involve back-to-back systems (Eagle Pass, USA), wind energy applications (Gotland, Sweden, and NORD E.ON 1, Germany), two controlled asynchronous connections for trading of electricity (MurrayLink and DirectLink, Australia), power enhancement (CrossSound link, USA, and Caprivi link, Namibia), and the powering of offshore platforms (Troll A and Valhall, Norway). It should be noted that the dc voltage has reached 350 kV and the largest system is at 400 MW, making the VSC-HVdc a well-established technology in the medium power levels. Irrespective of how challenging the applications are, the VSC-HVdc technology remains competitive and assists utilities worldwide in order to deliver efficient, reliable, economic, and (where possible) renewable energy to customers.

### IX. CONCLUSION

In this paper, recent advances of the VSC-based HVdc technology are presented. The development of high-voltage high-power semiconductors have successfully assisted utilities to exploit the benefits of the four-quadrant static converter interlinking two ac systems through HVdc with a number of key benefits, namely independent control of active and reactive power through the PWM control of the converter, fast dynamic response, and possibility to connect ac island with no synchronous generation in the grid. It is confirmed that developments associated with VSC-based HVdc technology have delivered systems at voltage levels up to 350 kV and power levels up to 400 MW. VSC-HVdc undoubtedly will continue to provide solutions in many areas of the power systems where installations necessitate proven solutions.

### REFERENCES

- [1] L. Gyugyi, "Reactive power generation and control by thyristor circuits," *IEEE Trans. Ind. Appl.*, vol. IA-15, no. 5, pp. 521–532, Sep./Oct. 1979.
- [2] L. Gyugyi, "Control of shunt compensation with reference to new design concepts," *Proc. Inst. Electr. Eng., Part C: Gener., Transmiss. Distrib.*, vol. 128, no. 6, pp. 374–381, 1981.
- [3] L. Gyugyi, "Power electronics in electric utilities: Static VAR compensators," *Proc. IEEE*, vol. 76, no. 4, pp. 483–494, Apr. 1988.
- [4] N. G. Hingorani, "Power electronics in electric utilities: Role of power electronics in future power systems," *Proc. IEEE*, vol. 76, no. 4, pp. 481–482, Apr. 1988.
- [5] K. R. Padiyar, *HVDC Power Transmission Systems: Technology and System Interactions*. New York/Chichester, U.K.: Wiley, 1990.
- [6] N. G. Hingorani, "FACTS-flexible AC transmission system," in *Proc. Inst. Electr. Eng. Conf. Publ.*, 1991, pp. 1–7.
- [7] L. Gyugyi, "Unified power-flow control concept for flexible AC transmission systems," *Proc. Inst. Electr. Eng. Part C: Gener., Transmiss. Distrib.*, vol. 139, no. 4, pp. 323–331, 1992.

- [8] N. G. Hingorani, "Flexible AC transmission," *IEEE Spectr.*, vol. 30, no. 4, pp. 40–45, Apr. 1993.
- [9] L. Gyugyi, "Dynamic compensation of AC transmission lines by solid-state synchronous voltage sources," *IEEE Trans. Power Del.*, vol. 9, no. 2, pp. 904–911, Apr. 1994.
- [10] N. G. Hingorani, "FACTS technology and opportunities," in *Proc. Inst. Electr. Eng. Colloq. Flexible AC Transmiss. Syst. (FACTS)—Key Increased Utilisation Power Syst.*, 1994, pp. 4/1–4/10, (Dig. No.1994/005).
- [11] N.G. Hingorani, "Future role of power electronics in power systems," in *Proc. 1995 Int. Symp. Power Semicond. Devices ICs*, Yokohama, Japan, 1995, pp. 13–15.
- [12] N. G. Hingorani, "High-voltage DC transmission: A power electronics workhorse," *IEEE Spectr.*, vol. 33, no. 4, pp. 63–72, Apr. 1996.
- [13] J. Arrillaga, *High Voltage Direct Current Transmission*. London, U.K.: Inst. Electr. Eng., 1998.
- [14] E. I. Carroll, "Power electronics for very high power applications," in *Proc. 7th Int. Conf. Power Electron. Variable Speed Drives*, 1998, pp. 218–223, (Inst. Electr. Eng. Conf. Publ. No. 456).
- [15] R. Grunbaum, M. Noroozian, and B. Thorvaldsson, "FACTS—Powerful systems for flexible power transmission," *ABB Rev.*, vol. 5, pp. 4–17, 1999.
- [16] Y. H. Song and A. Johns, *Flexible AC Transmission Systems (FACTS)*. London, U.K.: Inst. Electr. Eng., 1999.
- [17] N. G. Hingorani and L. Gyugyi, *Understanding FACTS: Concepts and Technology of Flexible AC Transmission Systems*. New York: IEEE Press, 2000.
- [18] D. Povh, "Use of HVDC and FACTS," *Proc. IEEE*, vol. 88, no. 2, pp. 235–245, Feb. 2000.
- [19] H. Akagi, "Large static converters for industry and utility applications," *Proc. IEEE*, vol. 89, no. 6, pp. 976–983, Jun. 2001.
- [20] N. G. Hingorani, "Future directions for power electronics," in *Proc. IEEE/PES Transmiss. Distrib. Conf. Expo.*, 2001, pp. 1180–1181.
- [21] E. Acha, V. G. Agelidis, O. Anaya-Lara, and T. J. E. Miller, *Power Electronic Control in Electrical Systems*, 1st ed. Oxford, U.K.: Newnes, 2002.
- [22] A. A. Edris, S. Zelingher, L. Gyugyi, and L. J. Kovalsky, "Squeezing more power from the grid," *IEEE Power Eng. Rev.*, vol. 22, no. 6, pp. 4–6, Jun. 2002.
- [23] R. M. Mathur and R. K. Varma, *Thyristor-Based Facts Controllers for Electrical Transmission Systems*. Piscataway, NJ/New York: IEEE Press/Wiley, 2002.
- [24] V. K. Sood, *HVDC and FACTS Controllers: Applications of Static Converters in Power Systems*. Boston, MA: Kluwer, 2004.
- [25] T. Ackermann, *Wind Power in Power Systems*. Chichester, U.K.: Wiley, 2005.
- [26] V. G. Agelidis, G. D. Demetriades, and N. Florentzou, "Recent advances in high-voltage direct-current power transmission systems," in *Proc. IEEE Int. Conf. Ind. Technol. (ICIT 2006)*, pp. 206–213.
- [27] M. P. Bahrman and B. K. Johnson, "The ABCs of HVDC transmission technologies," *IEEE Power Energy Mag.*, vol. 5, no. 2, pp. 32–44, Mar./Apr. 2007.
- [28] R. K. Varma, W. Litzemberger, S. Auddy, and D. Patel, "Bibliography of HVDC transmission: 2001–2003 part I IEEE working group report," in *Proc. IEEE Power Eng. Soc. Gen. Meeting*, 2007, pp. 1–8.
- [29] R. K. Varma, W. Litzemberger, and J. Berge, "Bibliography of FACTS: 2001—Part II IEEE working group report," in *Proc. IEEE Power Eng. Soc. Gen. Meeting*, 2007, pp. 1–6.
- [30] J. Arrillaga, Y. H. Liu, and N. R. Watson, *Flexible Power Transmission: The HVDC Options*. Chichester, U.K.: Wiley, 2007.
- [31] P. K. Steimer, H. E. Gruening, J. Werninger, E. Carroll, S. Klaka, and S. Linder, "IGCT—A new emerging technology for high power, low cost inverters," *IEEE Ind. Appl. Mag.*, vol. 5, no. 4, pp. 12–18, Jul./Aug. 1999.
- [32] P. Steimer, O. Apeldoorn, E. Carroll, and A. Nagel, "IGCT technology baseline and future opportunities," in *Proc. IEEE Transmiss. Distrib. Conf. Expo.*, 2001, pp. 1182–1187.
- [33] E. Carroll and J. Siefken, "IGCTS: Moving on the right track," in *Proc. Power Electron. Technol.*, 2002, vol. V. 26, pp. 16–18.
- [34] S. Gunturi, J. Assal, D. Schneider, and S. Eicher, "Innovative metal system for IGBT press pack modules," in *Proc. IEEE Int. Symp. Power Semicond. Devices ICs (ISPSD)*, Cambridge, U.K., 2003, pp. 110–113.
- [35] A. Kopta, M. Rahimo, U. Schlabach, D. Schneider, E. Carroll, and S. Linder, "A 6.5 kV IGBT module with very high safe operating area," in *Proc. 40th IAS Annu. Meeting Ind. Appl. Conf.*, 2005, pp. 794–798.



- [36] S. Gunturi and D. Schneider, "On the operation of a press pack IGBT module under short circuit conditions," *IEEE Trans. Adv. Packag.*, vol. 29, no. 3, pp. 433–440, Aug. 2006.
- [37] J. Casazza and G. C. Loehr, *The Evolution of Electric Power Transmission Under Deregulation: Selected Readings*. Piscataway, NJ: IEEE Press, 2000.
- [38] T. J. Hammons, M. Willingham, K. N. Mak, M. D. Silva, M. Morozowski, and B. K. Blyden, "Generation and transmission improvements in developing countries," *IEEE Trans. Energy Convers.*, vol. 14, no. 3, pp. 760–765, Sep. 1999.
- [39] T. J. Hammons, D. Woodford, J. Loughtan, M. Chamia, J. Donahoe, D. Povh, B. Bisewski, and W. Long, "Role of HVDC transmission in future energy development," *IEEE Power Eng. Rev.*, vol. 20, no. 2, pp. 10–25, Feb. 2000.
- [40] A. M. H. A. Karim, N. H. A. Maskati, and S. Sud, "Status of Gulf co-operation council (GCC) electricity grid system interconnection," in *Proc. IEEE Power Eng. Soc. Gen. Meeting*, 2004, pp. 1385–1388.
- [41] L. Weimers, "AC or DC: Which way should China go?" *Modern Power Syst.*, vol. 25, no. 8, pp. 11–17, 2005.
- [42] C. Ashmore, "Transmit the light fantastic [HVDC power transmission]," *IET Power Eng.*, vol. 20, no. 2, pp. 24–7, 2006.
- [43] L. Willis and N. Stig, "HVDC transmission: Yesterday and today," *IEEE Power Energy Mag.*, vol. 5, no. 2, pp. 22–31, Mar./Apr. 2007.
- [44] G. Asplund, "Ultra high voltage transmission," *ABB Rev.*, vol. 2, pp. 22–27, 2007.
- [45] G. Asplund, K. Eriksson, and K. Svensson, "DC transmission based on voltage source converters," in *Proc. CIGRE SCI4 Colloq. South Africa*, 1997, pp. 1–7.
- [46] G. Asplund, K. Eriksson, and K. Svensson, "HVDC light—DC transmission based on voltage-sourced converters," *ABB Rev.*, vol. 1, pp. 4–9, 1998.
- [47] G. Asplund, K. Eriksson, and O. Tollerz, "HVDC light: A tool for electric power transmission to distant load," in *Proc. VI Sepope Conf.*, Salvador, Brazil, 1998, pp. 1–7.
- [48] B. Andersen and C. Barker, "A new era in HVDC?" *Inst. Electr. Eng. Rev.*, vol. 46, no. 2, pp. 33–39, 2000.
- [49] G. Asplund, "Application of HVDC Light to power system enhancement," in *Proc. IEEE Power Eng. Soc. Winter Meeting*, 2000, pp. 2498–2503.
- [50] U. Axelsson, A. Holm, C. Liljegren, M. Aberg, K. Eriksson, and O. Tollerz, "The Gotland HVDC Light Project—Experiences from trial and commercial operation," in *CIGRE Conf.*, Amsterdam, The Netherlands, 2001, pp. 1–5.
- [51] K. Eriksson, "Operational experience of HVDC LIGHT," in *Proc. AC DC Conf. Transmiss.*, London, U.K., 2001, pp. 205–210.
- [52] A. Petersson and A. Edris, "Dynamic performance of the Eagle Pass back-to-back HVDC Light tie," in *Proc. 7th Int. Conf. AC-DC Power Transmiss.*, London, U.K., 2001, pp. 220–225, (Conf. Publ. No. 485).
- [53] T. F. Nestli, L. Stendius, M. J. Johansson, A. Abrahamsson, and P. C. Kjaer, "Powering Troll with new technology," *ABB Rev.*, vol. 2, pp. 15–19, 2003.
- [54] S. G. Johansson, L. Carlsson, and G. Russberg, "Explore the power of HVDC LIGHT—A Web based system interaction tutorial," in *Proc. IEEE PES Power Syst. Conf. Expo.*, New York, 2004, pp. 839–842.
- [55] L. Stendius and P. Jones, "The challenges of offshore power system construction-bringing power successfully to Troll A, one of the worlds largest oil and gas platform," in *Proc. 8th Inst. Electr. Eng. Int. Conf. AC DC Power Transmiss. (ACDC 2006)*, pp. 75–78.
- [56] A. Persson and L. Carlsson, "New technologies in HVDC converter design," in *Proc. AC DC Power Transmiss.*, London, U.K., 1996, pp. 387–392, (Inst. Electr. Eng. Conf. Publ.).
- [57] L. Carlsson, "Classical HVDC: Still continuing to evolve," *Modern Power Syst.*, vol. 22, no. 6, pp. 19–21, 2002.
- [58] J. Varley, "HVDC: Fifty years on," *Modern Power Syst.*, vol. 24, no. 10, pp. 18–20, 2004.
- [59] B. Dellby, G. Bergman, J. Karlstrand, and J. Kaumanns, "High-voltage cable technology," *ABB Rev.*, vol. 4, pp. 35–44, 2000.
- [60] A. Ericsson, M. Jeroense, J. Miller, L. Palmqvist, B. Railing, and P. Rifon, "HVDC light cable systems—The latest projects," in *Proc. Nordic Insul. Symp.*, 2003, pp. 107–116.
- [61] B. Drugge, H. Fuhrmann, S. Laihonen, and J. Mood, "DryQ—Dry and silent," *ABB Rev.*, vol. 1, pp. 17–21, 2005.
- [62] A. M. S. Atmadji and J. G. J. Sloot, "Hybrid switching: A review of current literature," in *Proc. IEEE Conf. Energy Manage. Power Del. (EMPD)*, Singapore, 1998, pp. 683–688.
- [63] G. B. D. Lange and A. M. Chol, "Novel application of PWM switching for DC traction circuit breakers," in *Proc. IEEE Int. Conf. Power Syst. Technol. (PowerCon)*, 2006, pp. 1–6.
- [64] T. Genji, O. Nakamura, M. Isozaki, M. Yamada, T. Morita, and M. Kaneda, "400 V class high-speed current limiting circuit breaker for electric power system," *IEEE Trans. Power Del.*, vol. 9, no. 3, pp. 1428–1435, Jul. 1994.
- [65] C. Meyer and R. W. D. Doncker, "LCC analysis of different resonant circuits and solid-state circuit breakers for medium-voltage grids," *IEEE Trans. Power Del.*, vol. 21, no. 3, pp. 1414–1420, Jul. 2006.
- [66] C. Meyer and R. W. D. Doncker, "Solid-state circuit breaker based on active thyristor topologies," *IEEE Trans. Power Electron.*, vol. 21, no. 2, pp. 450–458, Mar. 2006.
- [67] C. Meyer, S. Schroder, and R. W. D. Doncker, "Solid-state circuit breakers and current limiters for medium-voltage systems having distributed power systems," *IEEE Trans. Power Electron.*, vol. 19, no. 5, pp. 1333–1340, Sep. 2004.
- [68] L. Tang and B. T. Ooi, "Protection of VSC-multi-terminal HVDC against DC faults," in *Proc. IEEE Annu. Power Electron. Spec. Conf. (PESC)*, 2002, pp. 719–724.
- [69] W. Lu and B. T. Ooi, "DC overvoltage control during loss of converter in multiterminal voltage-source converter-based HVDC (M-VSC-HVDC)," *IEEE Trans. Power Del.*, vol. 18, no. 3, pp. 915–920, Jul. 2003.
- [70] A. Nabae, I. Takahashi, and H. Akagi, "A new neutral-point-clamp PWM inverter," *IEEE Trans. Ind. Appl.*, vol. IA-17, no. 5, pp. 518–523, Sep. 1981.
- [71] P. M. Bhagwat and V. R. Stefanovic, "Generalized structure of a multilevel PWM inverter," *IEEE Trans. Ind. Appl.*, vol. IA-19, no. 6, pp. 1057–1069, Nov. 1983.
- [72] T. A. Meynard and H. Foch, "Multi-level conversion: High voltage choppers and voltage-source inverters," in *Proc. IEEE Power Electron. Spec. Conf.*, 1992, pp. 397–403.
- [73] V. G. Agelidis, "A low-distortion multilevel pulse-width modulated inverter topology," in *Proc. IEEE Int. Symp. Ind. Electron. (ISIE)*, 1995, pp. 243–247.
- [74] J. S. Lai and F. Z. Peng, "Multilevel converters—A new breed of power converters," *IEEE Trans. Ind. Appl.*, vol. 32, no. 3, pp. 509–517, May/Jun. 1996.
- [75] F. Z. Peng, J. S. Lai, J. W. McKeever, and J. VanCoevering, "A multilevel voltage-source inverter with separate DC sources for static Var generation," *IEEE Trans. Ind. Appl.*, vol. 32, no. 5, pp. 1130–1138, Sep./Oct. 1996.
- [76] V. G. Agelidis and H. C. Goh, "Low-distortion variable-level PWM technique," *Proc. Inst. Electr. Eng. Electr. Power Appl.*, vol. 145, no. 2, pp. 73–78, 1998.
- [77] F. Z. Peng, J. W. McKeever, and D. J. Adams, "Power line conditioner using cascade multilevel inverters for distribution systems," *IEEE Trans. Ind. Appl.*, vol. 34, no. 6, pp. 1293–1298, Nov./Dec. 1998.
- [78] B. Bijlenga, "HVDC device for converting between alternating voltages and direct current voltages," U.S. Patent 6 480 403, 2002.
- [79] Y. H. Liu, J. Arrillaga, and N. R. Watson, "Cascaded H-bridge voltage reinjection—Part I: A new concept in multilevel voltage-source conversion," *IEEE Trans. Power Del.*, vol. 23, no. 2, pp. 1175–1182, Apr. 2008.
- [80] Y. H. Liu, J. Arrillaga, and N. R. Watson, "Cascaded H-bridge voltage reinjection—Part II: Application to HVDC transmission," *IEEE Trans. Power Del.*, vol. 23, no. 2, pp. 1200–1206, Apr. 2008.
- [81] A. Lesnicar and R. Marquardt, "An innovative modular multilevel converter topology suitable for a wide power range," in *Proc. IEEE PowerTech Conf.*, Bologna, Italy, 2003, pp. 1–6.
- [82] J. Dorn, H. Huang, and D. Retzmann, "Novel voltage-sourced converters for HVDC and FACTS applications," in *Proc. CIGRE Meeting 2007*, Osaka, Japan, pp. 314–321.
- [83] S. Allebrod, R. Hamerski, and R. Marquardt, "New transformerless, scalable modular multilevel converters for HVDC-transmission," in *Proc. IEEE Power Electron. Spec. Conf.*, Rhodes, Greece, 2008, pp. 174–179.
- [84] B. R. Andersen, L. Xu, P. J. Horton, and P. Cartwright, "Topologies for VSC transmission," *Power Eng. J.*, vol. 16, no. 3, pp. 142–50, 2002.
- [85] Y. H. Liu, J. Arrillaga, and N. R. Watson, "A new high-pulse voltage-sourced converter for HVDC transmission," *IEEE Trans. Power Del.*, vol. 18, no. 4, pp. 1388–1393, Oct. 2003.
- [86] L. B. Perera, N. R. Watson, Y. H. Liu, and J. Arrillaga, "Multilevel current reinjection self-commutated HVDC converter," *Proc. Inst. Electr. Eng. Gener., Transmiss. Distrib.*, vol. 152, no. 5, pp. 607–15, 2005.

- [87] B. T. Ooi and X. Wang, "Boost-type PWM HVDC transmission system," *IEEE Trans. Power Del.*, vol. 6, no. 4, pp. 1557–1563, Oct. 1991.
- [88] Z. Zhang, J. Kuang, X. Wang, and B. T. Ooi, "Force commutated HVDC and SVC based on phase-shifted multi-converter modules," *IEEE Trans. Power Del.*, vol. 8, no. 2, pp. 712–718, Apr. 1993.
- [89] J. Kuang and B. T. Ooi, "Series connected voltage-source converter modules for force-commutated SVC and DC-transmission," *IEEE Trans. Power Del.*, vol. 9, no. 2, pp. 977–983, Apr. 1994.
- [90] A. Lindberg and T. Larsson, "PWM and control of three level voltage source converters in an HVDC back-to-back station," in *Proc. AC DC Power Transmiss.*, London, U.K., 1996, pp. 297–302, (Inst. Electr. Eng. Conf. Publ.).
- [91] T. Nakajima, H. Suzuki, K. Sakamoto, M. Shigeta, H. Yamamoto, Y. Miyazaki, S. Tanaka, and S. Saito, "Multiple space vector control for self-commutated power converters," *IEEE Trans. Power Del.*, vol. 13, no. 4, pp. 1418–1424, Oct. 1998.
- [92] V. G. Agelidis and L. Xu, "A novel HVDC system based on flying capacitor multilevel PWM converters," in *Proc. CIGRE/IEEE PES Int. Symp. Quality Security Electr. Power Del. Syst. (CIGRE 2001)*, Wuhan, China, Sep. 2001.
- [93] L. Xu, V. G. Agelidis, and E. Acha, "Steady-state operation of HVDC power transmission systems with voltage-source converters and simultaneous Var compensation," presented at the Eur. Power Electron. Conf. (EPE 2001), Graz, Austria.
- [94] B. R. Andersen and L. Xu, "Hybrid HVDC system for power transmission to island networks," *IEEE Trans. Power Del.*, vol. 19, no. 4, pp. 1884–1890, Oct. 2004.
- [95] L. Xu and V. G. Agelidis, "A VSC transmission system using flying capacitor multilevel converters and selective harmonic elimination PWM control," in *Proc. 7th Int. Power Eng. Conf. (IPEC 2005)*, pp. 1176–1181.
- [96] L. Xu, B. R. Andersen, and P. Cartwright, "Multilevel-converter-based VSC transmission operating under fault AC conditions," *Proc. Inst. Electr. Eng. Gener., Transmiss. Distrib.*, vol. 152, no. 2, pp. 185–93, 2005.
- [97] L. Xu, B. R. Andersen, and P. Cartwright, "VSC transmission operating under unbalanced AC conditions—Analysis and control design," *IEEE Trans. Power Del.*, vol. 20, no. 1, pp. 427–434, Jan. 2005.
- [98] J. H. Liu, J. Arrillaga, N. R. Watson, and A. R. Wood, "Multi-level voltage reinjection VSC HVDC transmission," in *Proc. 8th Inst. Electr. Eng. Int. Conf. AC DC Power Transmiss. (ACDC 2006)*, pp. 130–134.
- [99] Y. H. Liu, L. B. Perera, A. Arrillaga, and N. R. Watson, "Application of the multi-level current reinjection concept to HVDC transmission," *IET Gener., Transmiss. Distrib.*, vol. 1, no. 3, pp. 399–404, 2007.
- [100] Y. H. Liu, L. B. Perera, J. Arrillaga, and N. R. Watson, "A back to back HVDC link with multilevel current reinjection converters," *IEEE Trans. Power Del.*, vol. 22, no. 3, pp. 1904–1909, Jul. 2007.
- [101] M. Saeedifard, H. Nikkhajoei, R. Iravani, and A. Bakshai, "A space vector modulation approach for a multimodule HVDC converter system," *IEEE Trans. Power Del.*, vol. 22, no. 3, pp. 1643–1654, Jul. 2007.
- [102] L. Xu and V. G. Agelidis, "VSC transmission system using flying capacitor multilevel converters and hybrid PWM control," *IEEE Trans. Power Del.*, vol. 22, no. 1, pp. 693–702, Jan. 2007.
- [103] V. G. Agelidis, A. I. Balouktsis, and M. S. A. Dahidah, "A five-level symmetrically defined selective harmonic elimination PWM strategy: Analysis and experimental validation," *IEEE Trans. Power Electron.*, vol. 23, no. 1, pp. 19–26, Jan. 2008.
- [104] V. G. Agelidis, A. I. Balouktsis, and C. Cossar, "On attaining the multiple solutions of selective harmonic elimination PWM three-level waveforms through function minimisation," *IEEE Trans. Ind. Electron.*, vol. 55, no. 3, pp. 996–1004, Mar. 2008.
- [105] J. L. Thomas, S. Poullain, and A. Benchaib, "Analysis of a robust DC-bus voltage control system for a VSC transmission scheme," in *Proc. 7th Int. Conf. AC-DC Power Transmiss.*, London, U.K., 2001, pp. 119–124, (Conf. Publ. No. 485).
- [106] Z. Huang, B. T. Ooi, L. A. Dessaint, and F. D. Galiana, "Exploiting voltage support of voltage-source HVDC," *Proc. Inst. Electr. Eng. Gener., Transmiss. Distrib.*, vol. 150, no. 2, pp. 252–6, 2003.
- [107] F. A. R. Al Jowder and B. T. Ooi, "VSC-HVDC station with SSSC characteristics," *IEEE Trans. Power Electron.*, vol. 19, no. 4, pp. 1053–1059, Jul. 2004.
- [108] C. Du and M. H. J. Bollen, "Power-frequency control for VSC-HVDC during island operation," in *Proc. 8th Inst. Electr. Eng. Int. Conf. AC DC Power Transmiss. (ACDC 2006)*, pp. 177–181.
- [109] A. Yazdani and R. Iravani, "Dynamic model and control of the NPC-based back-to-back HVDC system," *IEEE Trans. Power Del.*, vol. 21, no. 1, pp. 414–424, Jan. 2006.
- [110] Y. H. Liu, J. Arrillaga, and N. R. Watson, "Addition of four-quadrant power controllability to multi-level VSC HVDC transmission," *IET Gener., Transmiss. Distrib.*, vol. 1, no. 6, pp. 872–878, 2007.
- [111] P. Hao, W. Zanj, and C. Jianye, "Study on the control of shunt active DC filter for HVDC systems," *IEEE Trans. Power Del.*, vol. 23, no. 1, pp. 396–401, Jan. 2008.
- [112] W. Lu and B. T. Ooi, "Premium quality power park based on multi-terminal HVDC," *IEEE Trans. Power Del.*, vol. 20, no. 2, pp. 978–983, Apr. 2005.
- [113] H. Jiang and A. Ekstrom, "Multiterminal HVDC systems in urban areas of large cities," *IEEE Trans. Power Del.*, vol. 13, no. 4, pp. 1278–1284, Oct. 1998.
- [114] V. G. Agelidis and C. Mademlis, "Technology of offshore wind turbines and farms and novel multilevel converter-based HVDC systems for their grid connections," *Wind Eng.*, vol. 26, no. 6, pp. 383–395, 2002.
- [115] N. M. Kirby, L. Xu, M. Luckett, and W. Siepmann, "HVDC transmission for large offshore wind farms," *Power Eng. J.*, vol. 16, no. 3, pp. 135–141, 2002.
- [116] A. B. Morton, S. Cowdroy, J. R. A. Hill, M. Halliday, and G. D. Nicholson, "AC or DC? Economics of grid connection design for offshore wind farms," in *Proc. 8th Inst. Electr. Eng. Int. Conf. AC DC Power Transmiss. (ACDC 2006)*, London, U.K., pp. 236–240.
- [117] P. Bresesti, W. L. Kling, R. L. Hendriks, and R. Vailati, "HVDC connection of offshore wind farms to the transmission system," *IEEE Trans. Energy Convers.*, vol. 22, no. 1, pp. 37–43, Mar. 2007.
- [118] W. Lu and B. T. Ooi, "Multiterminal LVDC system for optimal acquisition of power in wind-farm using induction generators," *IEEE Trans. Power Electron.*, vol. 17, no. 4, pp. 558–563, Jul. 2002.
- [119] W. Lu and B. T. Ooi, "Optimal acquisition and aggregation of offshore wind power by multiterminal voltage-source HVDC," *IEEE Trans. Power Del.*, vol. 18, no. 1, pp. 201–206, Jan. 2003.
- [120] L. Xu, L. Yao, and C. Sasse, "Grid integration of large DFIG-based wind farms using VSC transmission," *IEEE Trans. Power Syst.*, vol. 22, no. 3, pp. 976–984, Aug. 2007.
- [121] L. Ran, D. Xiang, L. Hu, and K. Abbott, "Voltage stability of an HVDC system for a large offshore wind farm with DFIGs," in *Proc. 8th Inst. Electr. Eng. Int. Conf. AC DC Power Transmiss.*, 2006, pp. 150–154.
- [122] D. Xiang, L. Ran, J. R. Bumby, P. J. Tavner, and S. Yang, "Coordinated control of an HVDC link and doubly fed induction generators in a large offshore wind farm," *IEEE Trans. Power Del.*, vol. 21, no. 1, pp. 463–471, Jan. 2006.
- [123] L. Xu and P. Cartwright, "Direct active and reactive power control of DFIG for wind energy generation," *IEEE Trans. Energy Convers.*, vol. 21, no. 3, pp. 750–758, Sep. 2006.
- [124] S. Bozhko, R. V. Blasco-Gimenez, R. Li, J. Clare, and G. Asher, "Control of offshore DFIG-based wind farm grid with line-commutated HVDC connection," *IEEE Trans. Energy Convers.*, vol. 22, no. 1, pp. 71–78, Mar. 2007.
- [125] L. Xu and Y. Wang, "Dynamic modeling and control of DFIG-based wind turbines under unbalanced network conditions," *IEEE Trans. Power Syst.*, vol. 22, no. 1, pp. 314–323, Feb. 2007.
- [126] D. Zhi and L. Xu, "Direct power control of DFIG with constant switching frequency and improved transient performance," *IEEE Trans. Energy Convers.*, vol. 22, no. 1, pp. 110–118, Mar. 2007.
- [127] S. Bozhko, G. Asher, R. Li, J. Clare, and L. Yao, "Large offshore DFIG-based wind farm with line-commutated HVDC connection to the main grid: Engineering studies," *IEEE Trans. Energy Convers.*, vol. 23, no. 1, pp. 119–127, Mar. 2008.
- [128] A. Prasai, J. S. Yim, D. Divan, A. Bendre, and S. K. Sul, "A new architecture for offshore wind farms," *IEEE Trans. Power Electron.*, vol. 23, no. 3, pp. 1198–1204, May 2008.
- [129] W. Tang and R. H. Lasseter, "LVDC industrial power distribution system without central control unit," in *Proc. IEEE Annu. Power Electron. Spec. Conf. (PESC)*, 2000, pp. 979–984.
- [130] M. Brenna, G. C. Lazarou, and E. Tironi, "High power quality and DG integrated low voltage DC distribution system," in *Proc. IEEE Power Eng. Soc. Gen. Meeting (PES)*, Montreal, QC, Canada, 2006, pp. 1–6.
- [131] K. Fleischer and R. S. Munnings, "Power systems analysis for direct current (DC) distribution systems," *IEEE Trans. Ind. Appl.*, vol. 32, no. 5, pp. 982–989, Sep/Oct. 1996.

- [132] D. Nilsson and A. Sannino, "Efficiency analysis of low- and medium-voltage dc distribution systems," in *Proc. IEEE Power Eng. Soc. Gen. Meeting*, Denver, CO, 2004, pp. 2315–2321.
- [133] M. Furuse, S. Fuchino, N. Higuchi, and I. Ishii, "Feasibility study of low-voltage DC superconducting distribution system," *IEEE Trans. Appl. Supercond.*, vol. 15, no. 2, pp. 1759–1762, Jun. 2005.
- [134] A. Sannino, G. Postiglione, and M. H. J. Bollen, "Feasibility of a DC network for commercial facilities," *IEEE Trans. Ind. Appl.*, vol. 39, no. 5, pp. 1499–1507, Sep./Oct. 2003.



**Nikolas Florentzou** (S'07) received the B.Eng. degree (with honors) in electronics and communications engineering from the University of Birmingham, Birmingham, U.K., in 2002, and the joint M.Sc. degree in power electronics and drives from the University of Birmingham and the University of Nottingham, Nottingham, U.K., in 2003. He is currently working toward the Ph.D. degree in power systems at the University of Sydney, Sydney, N.S.W., Australia.

His current research interests include power electronic converters for power system applications.



**Vassilios G. Agelidis** (S'89–M'91–SM'00) was born in Serres, Greece. He received the B.S. degree in electrical engineering from the Democritus University of Thrace, Thrace, Greece, in 1988, the M.S. degree in applied science from Concordia University, Montreal, QC, Canada, in 1992, and the Ph.D. degree in electrical engineering from the Curtin University of Technology, Perth, W.A., Australia, in 1997.

From 1993 to 1999, he was with the School of Electrical and Computer Engineering, Curtin University of Technology. In 2000, he joined the Center

for Economic Renewable Power Delivery, University of Glasgow, Glasgow, U.K., as a Research Manager. He has authored or coauthored several journal and conference papers as well as *Power Electronic Control in Electrical Systems* (Newnes, 2002). From January 2005 to December 2007, he was the Inaugural Chair in Power Engineering in the School of Electrical, Energy, and Process Engineering, Murdoch University, Perth. Since January 2007, he has been the Energy Australia Chair of Power Engineering at the University of Sydney, Sydney, N.S.W., Australia.

Dr. Agelidis received the Advanced Research Fellowship from the U.K.'s Engineering and Physical Sciences Research Council (EPSRC-UK) in 2004. He was the Vice President Operations of the IEEE Power Electronics Society for 2006–2007. He was an Associate Editor of the IEEE POWER ELECTRONICS LETTERS from 2003 to 2005. He was the Power Electronics Society (PELS) Chapter Development Committee Chair from 2003 to 2005. He is currently an AdCom member of the IEEE PELS for 2007–2009. He has been the Technical Chair of the 39th IEEE PESC'08, Rhodes, Greece.



**Georgios D. Demetriades** (M'06) was born in Fama-gusta, Cyprus, in August 1967. He received the M.Sc. degree in electrical engineering at the Democritus University of Thrace, Thrace, Greece, the Technical Licentiate and Ph.D. degrees in power electronics from the Royal Institute of Technology (KTH), Stockholm, Sweden.

He was in Cyprus for two years period. In 1995, he joined ALSTOM Power Environmental Systems, Sweden. In 2000, he joined ABB Corporate Research, Västerås, Sweden, where he is currently a Research and Development Engineer. His current research interests include power electronics, high-frequency dc–dc power resonant converters, high-power converters, and high-frequency electromagnetic modeling.